

ANSCHÜTZ

EINFACH EINS WERDEN!

54.30 | 2013
1913 | 1907



OPERATING INSTRUCTIONS

MODEL

54.30 | 2013 | 1913 | 1907

J.G. ANSCHÜTZ GmbH & Co. KG

Jagd- und Sportwaffenfabrik

Daimlerstraße 12 · 89079 Ulm / Germany

Tel. +49 - (0)731-40 12 - 0 |

Fax +49 - (0)731-40 12 - 700



www.youtube.com/AnschuetzGmbH



www.facebook.com/OfficialAnschuetz

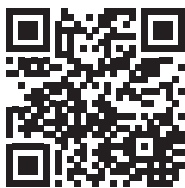

www.instagram.com/AnschuetzGmbH



www.anschuetz-sport.com

CONTENTS

1. COMPONENTS / DEFINITIONS	4
2. INTRODUCTION	5
3. SYMBOLS USED	5
3.1. GENERAL NOTES	5
3.2. SAFETY NOTES	5
4. GENERAL HANDLING OF GUNS	6
4.1. IMPORTANT PRINCIPLES	6
4.2. SHOOTING	7
4.3. MAINTENANCE	8
4.4. TRANSPORT	8
4.5. STORAGE	8
4.6. EAR AND EYE PROTECTION	8
5. LAWS	8
6. PROPER USE	8
7. LIABILITY	8
8. PRODUCT-SPECIFIC HANDLING	9
8.1. BOLT	9
8.1.1. Components / definitions	9
8.1.2. Cocking the bolt	9
8.1.3. Inserting the bolt	10
8.1.4. Removing the bolt	10
8.1.5. Maintenance of the bolt	11
8.1.5.1. Components / definitions	11
8.1.5.2. Disassembling the bolt	11
8.1.5.3. Assembling the bolt	13
8.1.6. Maintenance interval	13
8.2. SETTING / RELEASING THE SAFETY	13
8.2.1. Setting the safety	13
8.2.2. Releasing the safety	13
8.3. LOADING / REPEATING / SHOOTING / UNLOADING	14
8.3.1. Loading	14
8.3.2. Ready to fire	15
8.3.3. Unloading / making ready for storage	16
8.4. TRIGGER	17
8.4.1. Two stage trigger 5018	17
8.4.1.1. Components / definitions	17
8.4.1.2. Setting the trigger	17
8.4.1.2.1. Adjusting the trigger blade	17
8.4.1.2.2. Important information	17
8.4.1.2.3. Adjusting the trigger weight	18
8.4.1.2.4. Weight of first stage (only for two stage trigger)	18
8.4.1.2.5. Sear engagement	19
8.4.1.2.6. Setting of the sear engagement	19
8.4.1.2.7. The sear engagement is too long	19
8.4.1.2.8. The sear engagement is too short	20
8.4.1.2.9. First stage travel (only for two stage trigger)	20
8.4.1.2.10. Trigger stop	20

8.4.1.2.11.	Transformation of two stage trigger into single stage trigger	21
8.4.1.2.12.	Transformation from single stage trigger to two stage trigger	21
8.4.1.3.	Eliminating faults in the trigger	22
8.4.1.3.1.	The trigger catches the firing pin, but does not release when pulled.	22
8.4.1.3.2.	The trigger does not catch the firing pin	22
8.4.1.3.3.	The single stage trigger is set too short	22
8.4.1.3.4.	The catch lever retaining spring is too weak or defective	22
8.4.1.4.	Dry firing device	22
8.4.1.5.	Maintenance of the trigger	22
8.5.	BARRELED ACTION MOUNTING AND STOCK SETTINGS	23
8.5.1.	Precise stocks / Precise benchrest stocks	23
8.5.1.1.	Components / definitions	23
8.5.1.2.	Assembly / disassembly of stock and barreled action	23
8.5.1.2.1.	Assembly / disassembly of stock and barreled action for 54.30, 1913, and 1907 barreled actions	23
8.5.1.2.2.	Assembly / disassembly of stock and barreled action for 2013 barreled actions	24
8.5.1.3.	Adjusting the butt plate and butt plate carrier	25
8.5.1.3.1.	Components / definitions	25
8.5.1.3.2.	Adjusting the swivel hook	25
8.5.1.3.3.	Adjusting the hook and filling pieces	25
8.5.1.3.4.	Adjusting the shoulder flap	25
8.5.1.3.5.	Adjusting the tilting	26
8.5.1.3.6.	Adjusting the height	26
8.5.1.3.7.	Length adjustment of the butt plate carrier	26
8.5.1.3.8.	Tilt of the butt plate carrier.	26
8.5.1.4.	Adjusting the cheek piece	27
8.5.1.4.1.	Components/definitions.	27
8.5.1.4.2.	Adjusting the height	27
8.5.1.4.3.	Adjusting the cheek support.	27
8.5.1.5.	Adjusting the grip	27
8.5.1.6.	Adjusting the fore-end raiser block	28
8.5.1.7.	Mounting / dismounting the hand stop	28
8.5.1.8.	Adjusting the bench rest rail (PRECISE Benchrest)	28
8.5.2.	KK Match	29
8.5.2.1.	Components / definitions	29
8.5.2.2.	Assembly / disassembly of stock and barreled action for 54.30, 1913 and 1907.	29
8.5.2.3.	Adjusting the butt plate and butt plate carrier	29
8.5.2.3.1.	Components / definitions	29
8.5.2.3.2.	Adjusting the hook	29
8.5.2.3.3.	Adjusting the shoulder flap	30
8.5.2.3.4.	Adjusting the tilting	30
8.5.2.3.5.	Adjusting the height	30
8.5.2.3.6.	Length adjustment of the butt plate carrier	31
8.5.2.3.7.	Tilt of the butt plate carrier.	31
8.5.2.4.	Adjusting the cheek piece	31
8.5.2.4.1.	Components / definitions	31
8.5.2.4.2.	Adjusting the height	31
8.5.2.4.3.	Adjusting the cheek support.	31
8.5.2.5.	Mounting / dismounting the hand stop	32

8.5.3.	Benchrest	32
8.5.3.1.	Components / definitions	32
8.5.3.2.	Assembly / disassembly of stock and barreled action for 54.30, 1913 and 1907	32
8.5.3.3.	Adjusting the butt plate	33
8.5.4.	Maintenance / cleaning of the stock	33
8.6.	BARREL	34
8.6.1.	Mounting of the muzzle tube (optional)	34
8.6.2.	Cleaning the barrel	34
8.7.	SIGHTS / MOUNTING	35
8.7.1.	Rear sight (optional)	35
8.7.1.1.	Components / definitions	35
8.7.1.2.	Mounting / dismounting the rear sight.	35
8.7.1.3.	Elevation and windage of the shot point position	36
8.7.1.4.	Zero adjustment	36
8.7.1.5.	Tilting the rear sight	36
8.7.1.6.	Maintenance and cleaning of the rear sight	36
8.7.2.	Front sight (optional)	37
8.7.2.1.	Components / definitions	37
8.7.2.2.	Mounting / dismounting the front sight	37
8.7.2.3.	Mounting / dismounting the rear raiser bridge	38
9.	TROUBLESHOOTING	39
10.	DISPOSAL	39
11.	MISCELLANEOUS	39
12.	SHOOTING PERFORMANCE.	39
13.	GUARANTEE CARD	40

1. COMPONENTS / DEFINITIONS

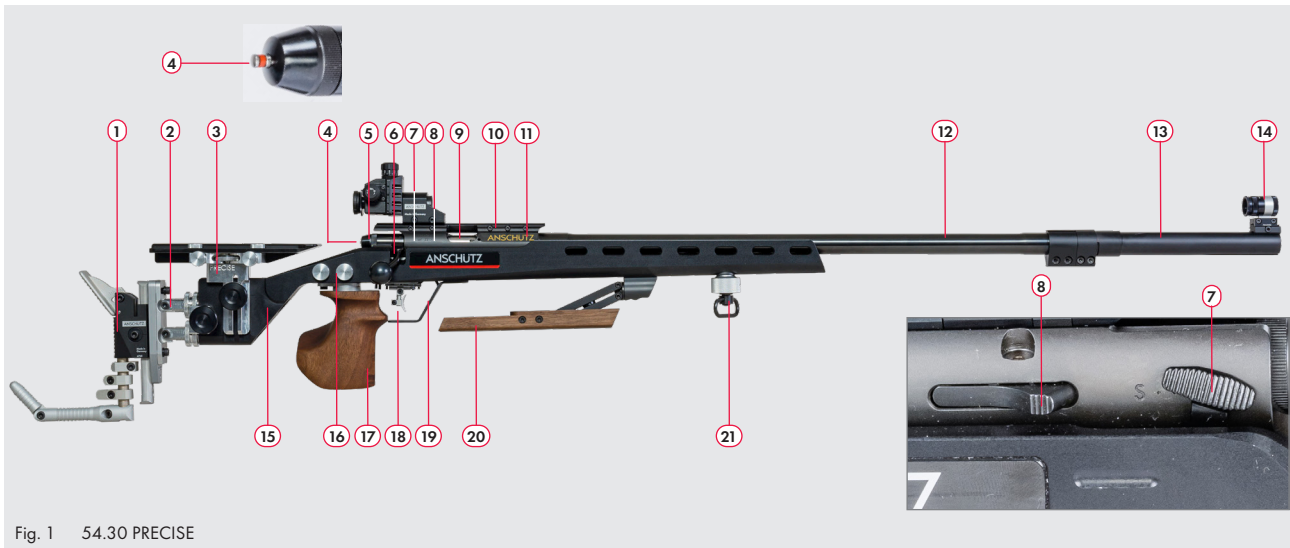

Fig. 1 54.30 PRECISE

- | | | | |
|-----------------------|------------------------|-------------------------------|---------------------------|
| 1. Hook butt plate | 7. Safety | 13. Muzzle tube | 19. Trigger guard |
| 2. Butt plate carrier | 8. Bolt catch | 14. Front sight | 20. Fore-end raiser block |
| 3. Cheek piece | 9. Ejection port | 15. Stock | 21. Hand stop |
| 4. Indicator pin | 10. Rear raiser bridge | 16. Set screws grip fastening | |
| 5. Bolt | 11. Receiver | 17. Grip | |
| 6. Bolt handle | 12. Barrel | 18. Trigger | |



Fig. 2 54.30 KK-Match (models 1913 and 1907 similar)



Fig. 3 54.30 PRECISE BENCHREST (models 1913 and 1907 similar)



Fig. 4 54.30 BENCHREST (models 1913 and 1907 similar)



Fig. 5 2013 PRECISE

NOTE



Your rifle may differ from the product depicted since this varies depending on model, year of manufacture, and equipment.

NOTE



The technical data do not apply to the entire model range. Specific model data may be found at www.anschuetz-sport.com.

2. INTRODUCTION

Dear Friend of ANSCHÜTZ:

You must be able to rely on a rifle's good qualities.

For example, its exact, consistent shooting performance. The ANSCHÜTZ barrels and detailed, sophisticated bolt construction guarantee you the best gunsmith quality.

ANSCHÜTZ incorporate more than 165 years' experience into its manufacturing of precision rifles. But of course tradition isn't everything.

Our hunting and target rifles are highly complex, coordinated systems. If you are not sure of how to operate and safely handle firearms, please ask us or your specialized dealer to prevent any possibly expensive repairs.

We have put various instruction manuals and possible settings for our products on our YouTube channel www.youtube.com/AnsuetzGmbH.

You can always count on the first-class quality of an ANSCHÜTZ rifle. Your ANSCHÜTZ rifle will always be a reliable companion with unmatched accuracy and function.

Your ANSCHÜTZ team

3. SYMBOLS USED

In these operating instructions, the following symbols are used for general and especially important details:

3.1. GENERAL NOTES

- ▶ identifies an action instruction.
- ✓ identifies the result of an action.
- identifies a list.
- ☛ identifies a note/additional information.

3.2. SAFETY NOTES

- ⚠ identifies a safety note.

! OBSERVE!



Observe the instructions for use!

! NOTE!



Prohibition that prescribes particular behavior!

! NOTE!



Hearing protectors should be used for your safety!

! NOTE!



Eye protection should be used for your safety!

⚠ CAUTION!



Indicates a dangerous situation that can cause bodily injuries, property damage or death.

GENERAL NOTES

4. GENERAL HANDLING OF GUNS

Guns can be dangerous objects, whose storage and use require particular caution. The following safety notes and warnings must absolutely be followed!

NOTE!



Before using a firearm, you must absolutely read all of the operating instructions. You may only give the firearm to someone else with these operating instructions.

NOTE!



The firearm laws of the country in question are authoritative and must be observed.

NOTE!













In addition to reading these operating instructions, please have your specialized dealer explain your firearm and train you in its use.

4.1. IMPORTANT PRINCIPLES

NOTE!



It is expressly recommended that you never use firearms under the influence of drugs, alcohol or medications. Your sight, dexterity, and judgment may be compromised. Good physical and mental health is the prerequisite for the use of a firearm. (Please also heed the currently valid legal framework.)

-  The use of a firearm is exclusively permitted for proper use.
-  Firearms owners are responsible for ensuring that their firearm is always, and especially during their absence, never within reach of and secure against access by children and other unauthorized persons.
-  Weapons may never be given to unauthorized persons.
-  Only original ANSCHÜTZ magazines may be used.
-  The specified capacity of the magazine may never be exceeded.
-  Changes to the rifle or the use of non-original ANSCHÜTZ magazines and accessories may cause malfunctions.
-  Severe and life-threatening injuries and damage can be caused by the use of incorrect ammunition, soiling in the barrel or incorrect cartridge components.
-  Firearms that exhibit safety-compromising changes may not be used. If you determine a defect or failure, the firearm must be unloaded and brought to an authorized gunsmith for repair.
-  In case of external effects (e.g., corrosion, dropping, etc.), the firearm must be checked by an authorized gunsmith.
-  A firearm must always be handled with the greatest of care and secured against falling.

4.2. SHOOTING

⚠️ WARNING!



Peril to life and causing of property damage!
Aiming with the muzzle at people and objects.

- ▶ When the firearm is not being used, hold the muzzle in a safe direction.
- ▶ A muzzle may never be held in a direction in which it can cause damage or endanger life.

⚠️ CAUTION!



Malfunction when shooting!
Shot did not release when the trigger was pulled.

- ▶ Do not look into the muzzle.
- ▶ Hold the muzzle in a safe direction.
- ▶ Unload the firearm.
- ▶ Remove residues from the barrel.

- ⚠️ Every firearm must be treated as if it were loaded.
- ⚠️ Never pick up a firearm by the trigger.
- ⚠️ Shooting ranges must be sufficiently ventilated.
- ⚠️ A bullet trap in the shooting range must be completely safe and visible.
- ⚠️ When shooting, no people may linger near the target.
- ⚠️ In case of poor visibility conditions, a firearm should not be used.
- ⚠️ Do not shoot into the air, at hard or smooth surfaces, bodies of water, or targets on the horizon.
- ⚠️ Do not shoot at targets off which the bullet can ricochet or be diverted.

- ⚠️ When ready to fire, never hold the muzzle of a firearm under water or on materials or objects in order to prevent an accident or damage to your rifle.
- ⚠️ Only shoot the caliber specified on the barrel of the firearm.
- ⚠️ Only clean, factory-loaded, new ammunition in the caliber approved for the rifle may be used.
- ⚠️ Ammunition must comply with the specifications of the C.I.P.
- ⚠️ Only load the firearm immediately before use.
- ⚠️ Only original ANSCHÜTZ magazines may be used.
- ⚠️ The specified capacity of the magazine may never be exceeded.
- ⚠️ The use of incorrect ammunition, soiling in the barrel or incorrect cartridge components can cause life-threatening injuries and property damage.
- ⚠️ Only original ANSCHÜTZ parts may be used.

GENERAL NOTES

4.3. MAINTENANCE

- ⚠ Before and after use, or in case of maintenance and cleaning work, ensure that the firearm is not loaded.

4.4. TRANSPORT

- ⚠ Firearms may only be transported unloaded and in locked containers.
- ⚠ If you transport your firearm in a suitcase or a soft case, always make sure that the firearm and the inside of the suitcase or soft case are dry.
- ⚠ Only transport weapons in a dry and clean condition.

4.5. STORAGE

- ⚠ Firearms that are not in use must, in compliance with the currently applicable laws, be kept under lock and key.
- ⚠ Firearms must always be stored unloaded and uncocked.
- ⚠ Ammunition must be kept in a separate place under lock and key.

4.6. EAR AND EYE PROTECTION

NOTE!



When shooting, approved eye protection should be used for your safety! Shooting without safety equipment can cause vision damage.

NOTE!



When shooting, approved hearing protectors should be used for your safety! Shooting without safety equipment can cause hearing damage.

5. LAWS

NOTE!



The valid firearm laws, regulations, and provisions of the country in question as well as the safety rules of hunting and sports ordinances must be heeded.

6. PROPER USE

This firearm is a sport rifle.

It is to be used exclusively for and on shooting ranges (for sport disciplines) and may only be used by people with proper firearms permits.

The use is subject exclusively to the "General technical rules" for all shooting sport disciplines of the INTERNATIONAL SHOOTING SPORT FEDERATION (ISSF) and the rules of the INTERNATIONAL BIATHLON UNION, E-Mail: biathlon@ibu.at.

NOTE!



The use of a firearm is exclusively permitted for proper use.

7. LIABILITY

J.G. ANSCHÜTZ GmbH & Co. KG assumes no liability or claims for damages of any type due to:

- Failure to follow these operating instructions.
- Improper handling or repair.
- Use of non-original ANSCHÜTZ parts.
- Incorrect handling or maintenance.
- Any type of carelessness.
- Removal of seals or sealing lacquer.
- Unauthorized interventions.
- Transport damage that is not the fault of ANSCHÜTZ

can occur.

CAUTION!



Changes and manipulations to the firearm or its parts are prohibited and under some circumstances, may violate the guarantee provisions. Such changes can compromise the safe use of the product and cause accidents that put life and limb at risk. In such as case, the guarantee is automatically voided.

- ⚠ Examine the firearm for changes before each use.

8. PRODUCT-SPECIFIC HANDLING

8.1. BOLT

NOTE



For some models, the rifle and the bolt are packaged separately for safety reasons and must be put together.

NOTE!



Before first use of the firearm, the bolt and inside of the barrel must be de-oiled lint-free.

8.1.1. COMPONENTS / DEFINITIONS

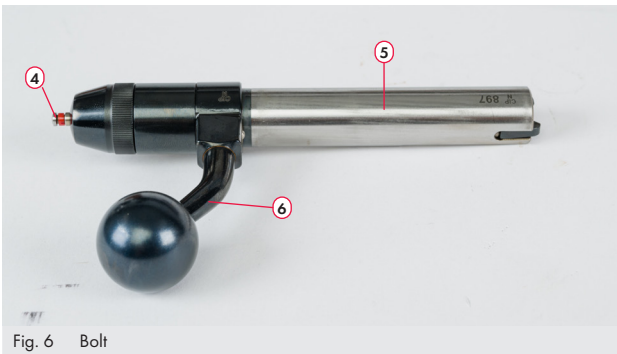

Fig. 6 Bolt

4 Indicator pin

6 Bolt handle

5 Bolt

f

8.1.2. COCKING THE BOLT

The bolt [5] must be cocked so that it can be installed in the receiver [11]. If the bolt has been removed from the receiver and uncocked for cleaning or inspection, the bolt must be cocked manually before it is installed again. Cock the bolt as follows:



Fig. 7 Bolt uncocked, indicator pin [4] not visible

- ▶ Wipe excess oil from the bolt.

CAUTION!



Risk of injury!

- ▶ When cocking the bolt, make sure your fingers do not get caught!

- ▶ Hold the bolt firmly and turn the bolt handle [6] counter-clockwise.

- ✓ When it is cocked, the indicator pin is [4] completely visible.



Fig. 8 Cocking the bolt



Fig. 9 Bolt cocked, indicator pin visible

- ✓ The bolt [5] is now cocked and can be installed in the receiver [11].

8.1.3. INSERTING THE BOLT

⚠ WARNING!



Mortal danger!
Due to ammunition in chamber
or magazine.

- ▶ Make sure that there is no ammunition in the rifle.

⚠ CAUTION!



Property damage!

- ▶ When inserting the bolt, make sure not to damage the stock.

ℹ NOTE!



To insert the bolt, the bolt catch [8] must not be pressed.

- ▶ Place cocked bolt [5] on the receiver [11] and push the bolt forward up to the stud (direction of arrow).



Fig. 10 Inserting the bolt

- ▶ The bolt catch [8] snaps in automatically.
- ▶ Press the bolt handle [6] down.



Fig. 11 Closing the bolt handle

- ✓ The bolt is inserted and cocked.

8.1.4. REMOVING THE BOLT

⚠ CAUTION!



Property damage!

- ▶ When removing the bolt, be sure not to damage the stock.

Here's how to remove the bolt:

- ▶ Open the bolt in the direction of the arrow and pull up to the stud.



Fig. 12 Opening the bolt

- ▶ Press the bolt catch [8] and hold it down.



Fig. 13 Pressing the bolt catch and holding it down

- ▶ When the bolt catch is pressed, pull the bolt out of the receiver [11] in the direction of the arrow.



Fig. 14 Removing the bolt

- ✓ The bolt is removed.

8.1.5. MAINTENANCE OF THE BOLT

8.1.5.1. COMPONENTS / DEFINITIONS



Fig. 15 Bolt [V]

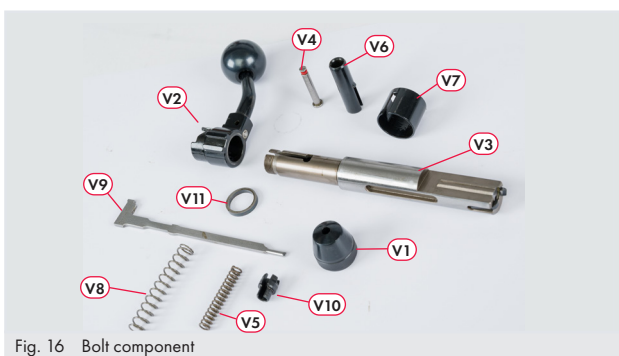

Fig. 16 Bolt component

- | | |
|-------------------------|-------------------------------------|
| V1. End cap | V7. Cover sleeve |
| V2. Bolt handle | V8. Compression spring (firing pin) |
| V3. Bolt body | V9. Firing pin |
| V4. Indicator pin | V10. Front spring support |
| V5. Compression spring | V11. Bearing ring |
| V6. Rear spring support | |

8.1.5.2. DISASSEMBLING THE BOLT

WARNING!



Only by an authorized gunsmith!

- ▶ Failure to follow these instructions voids the guarantee and any claims for damages.

- ▶ Removing the bolt [See "8.1.4. Removing the bolt" on page 10].

CAUTION!



Risk of injury!

- ▶ When cocking the bolt, make sure your fingers do not get caught!

- ▶ Uncock the bolt [V] (turn the bolt handle [V2] clockwise in the direction of the arrow to the right).



Fig. 17 Turning the bolt handle [V2] clockwise

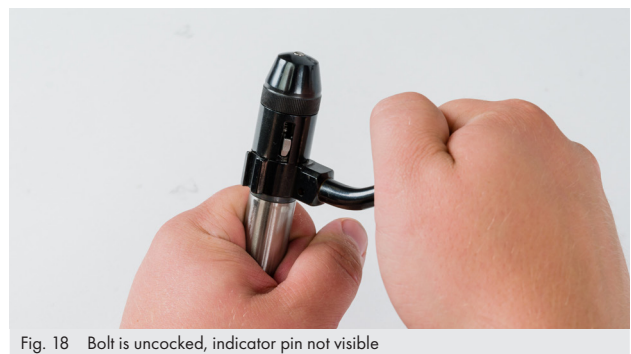

Fig. 18 Bolt is uncocked, indicator pin not visible

- ✓ The indicator pin protruding in the cocked state [V4] penetrates completely into the inside of the bolt.
- ▶ Unscrew the rear end cap [V1].



Fig. 19 Unscrewing the end cap [V1]

- ▶ All other bolt parts can now be removed in sequence.
- ▶ Remove the rear spring support [V6].



Fig. 20 Carefully pull out the spring support [V6]

- ▶ Remove the cover sleeve [V7].



Fig. 21 Removing the cover sleeve [V7]

- ▶ Pull out the firing pin [V9] with compression spring [V8].



Fig. 22 Removing the firing pin [V9]

- ▶ Remove the bolt handle [V2].



Fig. 23 Removing the bolt handle [V2]

- ▶ Push the front spring support [V10] back to the stud and turn slightly to the right or left (approx. 1/4 turn).

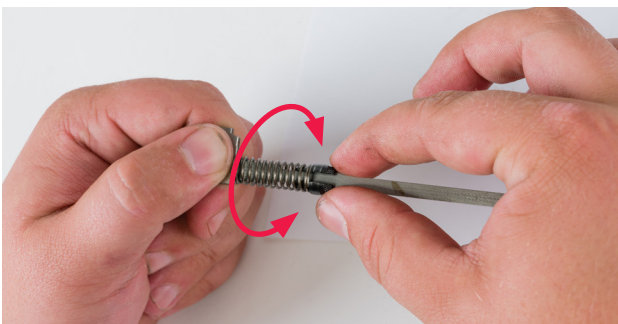

Fig. 24 Aligning the front spring support [V10]

- ▶ The front spring support [V10] including the compression spring [V8] can be pulled forward from the firing pin [V9].

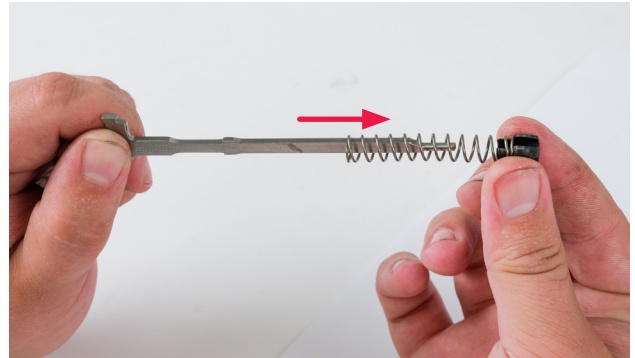

Fig. 25 Pulling off the front spring support [V10]



Fig. 26 Bolt taken apart

- ✓ The bolt is now disassembled and can be cleaned.

! NOTE!



Clean dirt and powder residues from all parts of the disassembled bolt with a thin, non-resinous oil. Then coat the components of the bolt with a light oil film.

8.1.5.3. ASSEMBLING THE BOLT

▶ Assembly is done in the reverse order.

NOTE!



The completely assembled bolt must be cocked before inserting it into the receiver.

NOTE!



ANSCHÜTZ recommends having the head-space checked by an authorized gunsmith at regular intervals.

8.1.6. MAINTENANCE INTERVAL

For optimal performance, ANSCHÜTZ recommends having the firing pin springs [V8] replaced by an authorized gunsmith every 5 years or after shooting 50,000 shots.

8.2. SETTING / RELEASING THE SAFETY

NOTE!



The firearm's safety can only be set/released when it is cocked, e.g. with open bolt (firing pin cocked) or after the loading procedure/closed bolt (firing pin and trigger cocked). The general process "setting/releasing the safety" will be described below.

8.2.1. SETTING THE SAFETY

NOTE!



The safety catch must catch in a notch exactly and may not be between the end stops.

▶ Push the safety catch [7] to the back (in the direction of the arrow) ("S" is visible).



Fig. 27 Firearm's safety is set

- ✓ The firearm is cocked and the safety set.
- ✗ The indicator pin [4] is visible.

8.2.2. RELEASING THE SAFETY

▶ Push the safety catch [7] forward (in the direction of the arrow) ("F" is visible).



Fig. 28 Safety catch "Ready to fire"

- ✓ The firearm is cocked and the safety released.

8.3. LOADING / REPEATING / SHOOTING / UNLOADING

8.3.1. LOADING

⚠ WARNING!



Mortal danger
Incorrect caliber in the chamber.

- ▶ Only use the caliber specified on the barrel.

⚠ CAUTION!



Only use ammunition with a muzzle speed V_0 of at least 280 m/s (920 fps). Failure to follow these instructions shall mean that the manufacturer assumes no liability and it voids the guarantee.

⚠ WARNING



Only load the firearm immediately before use.

- ▶ Open the bolt [5] (pull in the direction of the arrow up to the stud).

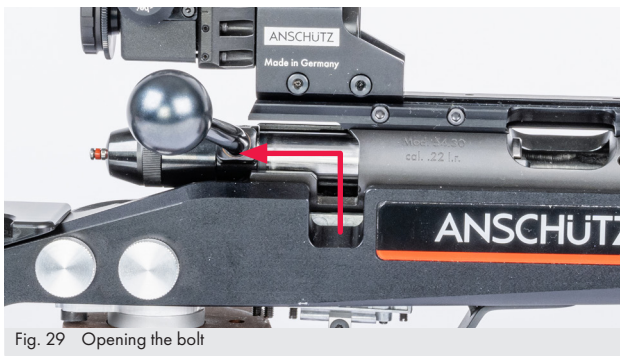

Fig. 29 Opening the bolt

- ▶ Set the firearm's safety [See "8.2.1. Setting the safety" on page 13]!
- ▶ Place the cartridge (with the bullet to the front) carefully in the ejection port [9] (the bullet may not be damaged).

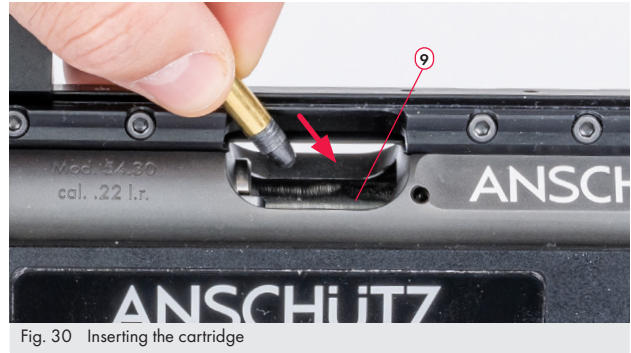



Fig. 30 Inserting the cartridge

ⓘ NOTE!



By closing the bolt, the cartridge is fed into the chamber [12].

- ▶ Close the bolt (push in the direction of the arrow up to the stud and press the receiver lever [6] down).

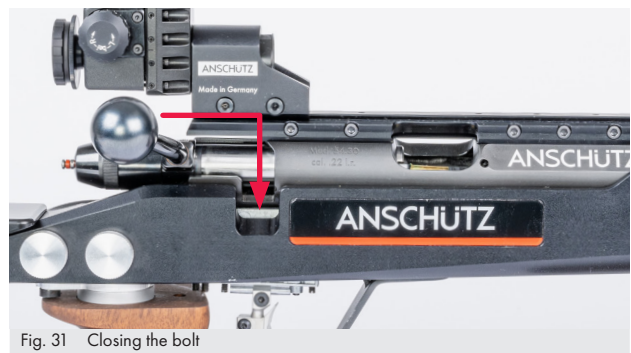

Fig. 31 Closing the bolt



Fig. 32 Bolt closed, firearm's safety set, loaded and cocked

- ✓ The firearm is now ready to shoot (safety set, loaded, and cocked).

⚠ WARNING!

Mortal danger
Unintentional shooting due to loaded,
unsecured firearm.

- ▶ Hold the muzzle in a safe direction.
- ▶ After loading, set the firearm's safety.

⚠ WARNING!

Mortal danger
Unintentional shooting due to inattention
when setting the firearm's safety or possible
malfunctions after setting the safety.

- ▶ Even when the safety is set, the muzzle
may never be held in a direction in which
it can cause damage or endanger life.

8.3.2. READY TO FIRE**⚠ WARNING**

Mortal danger!

- ▶ Check whether the action area is free and
the safety is set.
- ▶ Load and release the safety on your rifle
only immediately before you are ready
to fire.
- ▶ Set the safety and unload the rifle after
you are ready to fire.

- ▶ The rifle is ready to fire after "load" (See chapter
"8.3.1. Loading" on page 14). To be ready to fire,
actuate the safety catch [7] on the rifle and then slide
forwards ("F" is visible) and carefully aim at the target
and pull the trigger.
- ▶ To shoot again, lift up the bolt handle [6] and pull the
bolt up to the stud against the bolt catch [8].
- ▶ The cartridge in the receiver is ejected.
- ▶ To shoot again, perform the "load" procedure
[See "8.3.1. Loading" on page 14] again.

! NOTE!

By closing the bolt, the cartridge is fed into
barrel.

⚠ WARNING!

Mortal danger!
Unintentional shooting due to loaded,
unsecured firearm.

- ▶ Hold the muzzle in a safe direction.
- ▶ After loading, set the firearm's safety.

⚠ WARNING!

Mortal danger!
Unintentional shooting due to inattention
when setting the firearm's safety or possible
malfunctions after setting the safety.

- ▶ Even when the safety is set, the muzzle
may never be held in a direction in which
it can cause damage or endanger life.

8.3.3. UNLOADING / MAKING READY FOR STORAGE

It is recommended that you keep the rifle with uncocked bolt [5]. This extends the life span of the firing pin spring and maintains reliable firing of the cartridge. Follow the steps below to make the sport rifle ready for storage.

- ☛ It is possible to load and unload this rifle in the safe position.

⚠ WARNING!

⚠ Mortal danger!
Unintentional shooting due to loaded, unsecured firearm.

- ▶ Hold the muzzle in a safe direction.
- ▶ Make sure that there is no ammunition in the receiver [11] before you perform this procedure.

- ▶ Lift up the bolt handle. This cocks the bolt and the indicator pin becomes visible.
- ▶ Secure the firearm immediately and make sure that the safety catch [7] is set to "safe" ("S" is visible). (Only possible with cocked bolt, indicator pin is visible).
- ▶ Pull the bolt [5] up to the stud against the bolt catch [8].

📌 NOTE!

⚠ Any cartridge still in the receiver [11] or in the chamber is ejected.

- ▶ Make sure that there is no ammunition in the receiver [11] or in the chamber.
- ▶ Release the safety on the rifle by actuating the safety catch [7] on the rifle and sliding forwards ("F" is visible).
- ▶ Hold the rifle in a safe direction and pull the trigger [18] to the rear position. This is best done with your left hand.



Fig. 33 Holding the trigger down

- ▶ Push the bolt [5] carefully forwards and close the bolt handle [6] slowly. This way, the firing pin (indicator pin) [4] inside the bolt can move safely forward and it reduces the pressure of the firing pin spring.



Fig. 34 Close the bolt, indicator pin not visible

- ✓ The firearm is now unloaded, uncocked, the safety is released, and it is ready for storage.
- ☛ The indicator pin [4] is not visible.

8.4. TRIGGER

8.4.1. TWO STAGE TRIGGER 5018

Delivery state:

- ☛ The 5018 trigger is delivered from the factory as a two stage trigger with a set trigger weight of 125 g.

8.4.1.1. COMPONENTS / DEFINITIONS

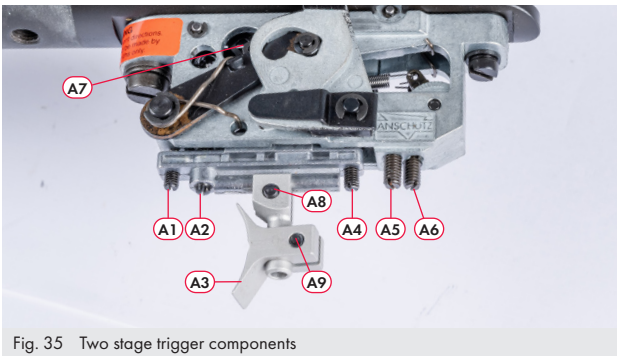

Fig. 35 Two stage trigger components

- | | |
|-------------------------------------|-------------------------------|
| A1. First stage set screw | A6. Trigger weight set screw |
| A2. Two stage set screw | A7. Trigger cam |
| A3. Trigger blade | A8. Clamping screw lengthwise |
| A4. Trigger stop set screw | A9. Clamping screw sideways |
| A5. Weight of first stage set screw | |

8.4.1.2. SETTING THE TRIGGER

8.4.1.2.1. ADJUSTING THE TRIGGER BLADE

The trigger blade can be pushed both lengthwise [A8] along the guide and swiveled sideways [A9].

- ▶ To set the trigger blade, loosen the clamping screws [A8] and [A9], make the desired settings, and then tighten the clamping screws again.

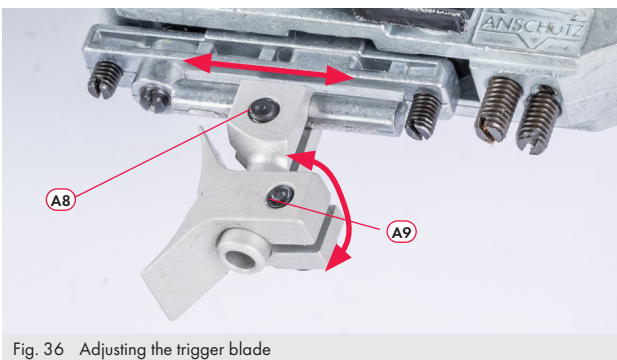

Fig. 36 Adjusting the trigger blade

- ✓ The trigger blade is set.

8.4.1.2.2. IMPORTANT INFORMATION

CAUTION:

The following settings on the trigger may only be made by a specialist who has received training by and at ANSCHÜTZ on the maintenance of ANSCHÜTZ target triggers!

⚠ WARNING!



Mortal danger!

Mortal danger due to loaded firearm.

- ▶ Do not look into the muzzle.
- ▶ Hold the muzzle in a safe direction.
- ▶ Make sure that the rifle is unloaded.

⚠ WARNING!



Mortal danger due to automatic firing!

Automatic shooting and malfunctions due to minimally set trigger weight and too-low sear engagement.

- ▶ Do not set the trigger weight too low.
- ▶ Do not set the sear engagement too low.

⚠ CAUTION!



Property damage!

- ▶ When changing the trigger, open or remove the bolt.

8.4.1.2.3. ADJUSTING THE TRIGGER WEIGHT

Adjusting the trigger weight with the trigger weight set screw [A6].

- ▶ Turn to the right = trigger weight increases (+).
- ▶ Turn to the left = trigger weight decreases (-).

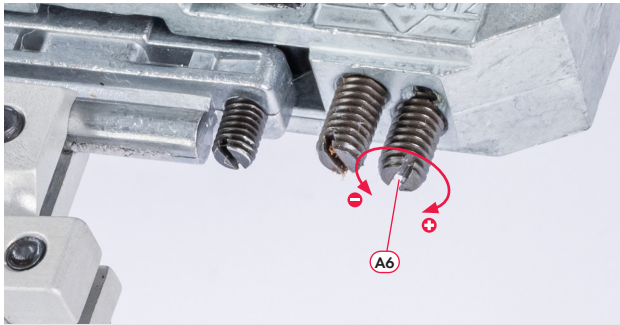

Fig. 37 Adjusting the trigger weight [A6]

NOTE



The trigger and weight of first stage depend mechanically on one another. Any adjustment always has a slight even change of the trigger and weight of first stage as its consequence.

Pushing the trigger cam [A7]:

- ▶ Lowest setting of the cam = lightest trigger weight
- ▶ Highest setting of the cam = highest trigger weight

NOTE!



Pushing the trigger cam requires a 2 mm hexagon key and perhaps also a tweezers.

- ▶ Turn to the left = loosen set screw
- ▶ Turn to the right = tighten set screw

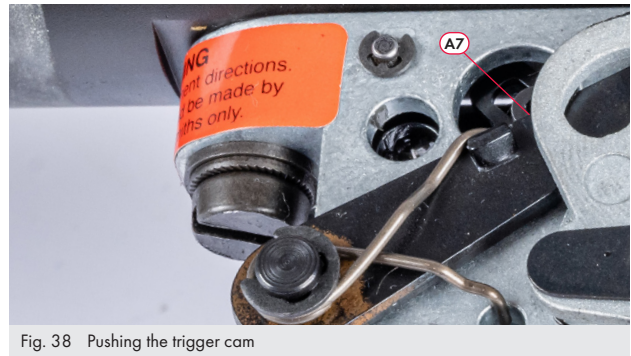

Fig. 38 Pushing the trigger cam

After pushing the trigger cam, the sear engagement (See chapter "8.4.1.2.5. Sear engagement" on page 19) must be checked and readjusted if necessary.

The fine adjustment of the trigger and weight of first stage is set with the set screws [A6] and [A5].

8.4.1.2.4. WEIGHT OF FIRST STAGE (ONLY FOR TWO STAGE TRIGGER)

NOTE!



The trigger and weight of first stage depend mechanically on one another. Any adjustment always has a slight even change of the trigger and weight of first stage as its consequence.

Adjusting the weight of the first stage with the set screw [A5]:

- ▶ Turn to the right = weight of first stage increases (+).
- ▶ Turn to the left = weight of first stage decreases (-).

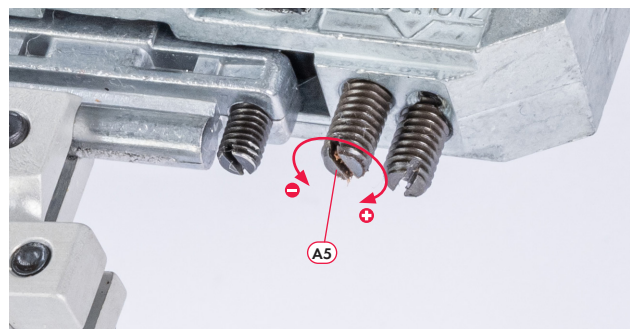

Fig. 39 Adjusting the weight of first stage

8.4.1.2.5. SEAR ENGAGEMENT

The sear engagement refers to the path from the two stage to the releasing of the trigger.

⚠ WARNING!



Mortal danger!
Unintentional shooting due to too-low sear engagement and / or too-low trigger weight.

- ▶ Sear engagement is set too low.
- ▶ Trigger weight is set too low.
- ▶ Do not subject a loaded firearm with the safety released to shocks and do not close the bolt with force.

8.4.1.2.6. SETTING OF THE SEAR ENGAGEMENT

Adjustment of the sear engagement with two stage trigger via set screw [A2]:

- ⚠ The firearm must be unloaded, (See chapter "8.3. Loading / repeating / shooting / unloading" on page 14).
- ▶ Turn to the right = sear engagement is shortened(-).
- ▶ Turn to the left = sear engagement is lengthened(+).

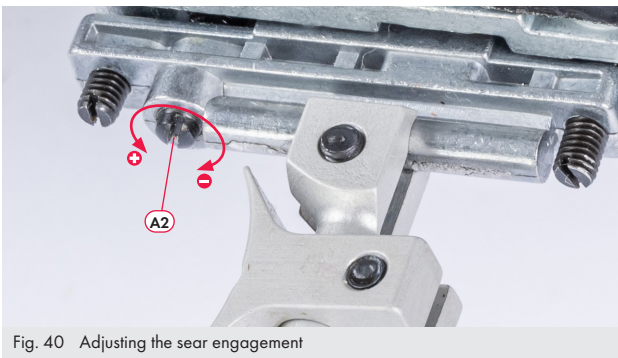

Fig. 40 Adjusting the sear engagement

- ▶ Cock the firearm and release the trigger (check whether the trigger releases as desired).

8.4.1.2.7. THE SEAR ENGAGEMENT IS TOO LONG

There is a short path from the two stage to the release of the trigger (so-called "pulling" or "dragging").

- ▶ Turn the two stage set screw [A2] step by step to the right after cocking and releasing (in each case approx. 1/8 turn).
- ▶ Repeat the procedure until no more two stage is palpable.
- ▶ Then turn back 1/8 turn to the left.
- ✓ The optimal sear engagement is set.

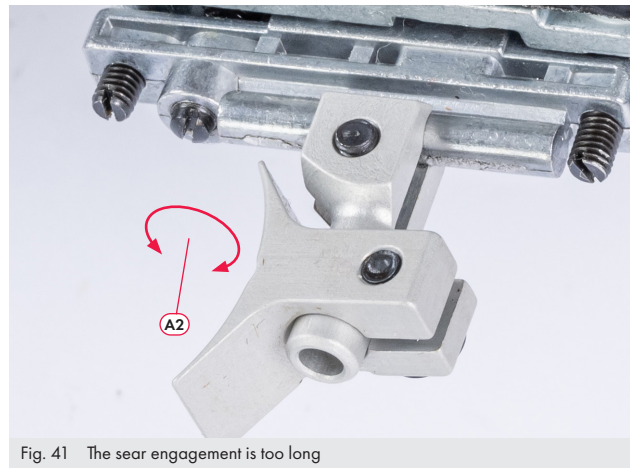

Fig. 41 The sear engagement is too long

8.4.1.2.8. THE SEAR ENGAGEMENT IS TOO SHORT

There is no more two stage. The trigger releases indefinitely without two stage.

- ▶ Turn the two stage set screw [A2] at least ¼ turn to the left after cocking, release the trigger and check whether there is a two stage.
- ▶ If not, repeat the procedure until there is an audible two stage.
- ▶ As soon as there is a palpable two stage, proceed according to (See chapter "8.4.1.2.7. The sear engagement is too long" on page 19) in order to get the optimal sear engagement.

Adjustment of the sear engagement with single stage trigger via set screw [A2]. (See chapter "8.4.1.2.11. Transformation of two stage trigger into single stage trigger" on page 21)

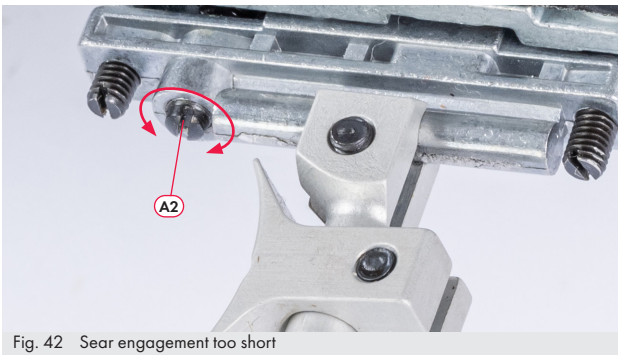

Fig. 42 Sear engagement too short

8.4.1.2.9. FIRST STAGE TRAVEL (ONLY FOR TWO STAGE TRIGGER)

⚠ WARNING!



Mortal danger!
First stage travel set screw [A1] is set via the two stage function.

- ▶ Never turn the first stage travel set screw with the two stage function.
- ▶ Never eliminate the first stage travel entirely in order to transform a two stage trigger into a single stage trigger.

The path of the trigger blade [A3] from the zero position to the two stage is called the first stage travel.

Adjusting the first stage travel with the set screw [A1]:

- ▶ Turn to the right = first stage travel is shortened (-)
- ▶ Turn to the left = first stage travel is lengthened (+)

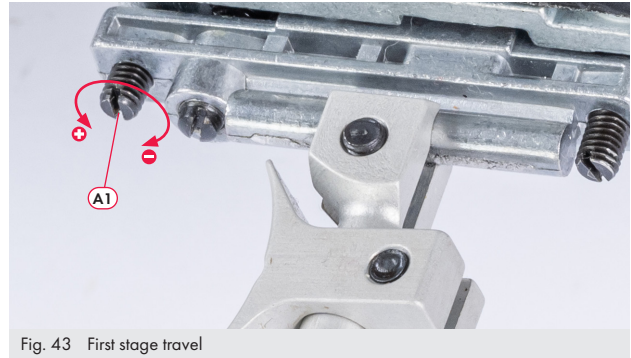

Fig. 43 First stage travel

8.4.1.2.10. TRIGGER STOP

⚠ CAUTION!



Malfunction!
Trigger stop set screw [A4] is turned beyond the release point (trigger does not release).

- ▶ Do not tighten the trigger stop set screw beyond the release point.

The trigger stop refers to the path from the two stage to the stud of the trigger blade [A3].

Adjusting the trigger stop with the trigger stop set screw [A4]:

- ▶ Turn to the right = trigger stop is shortened (-)
- ▶ Turn to the left = trigger stop is lengthened (+)

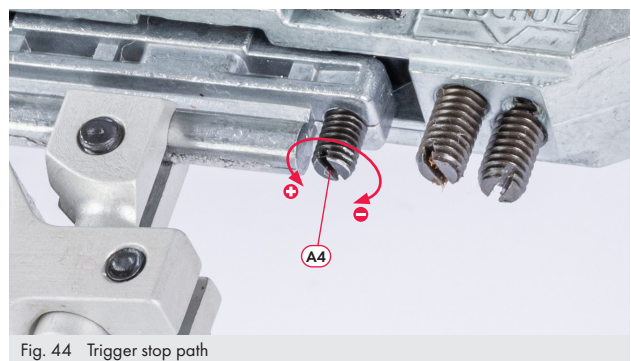

Fig. 44 Trigger stop path

8.4.1.2.11. TRANSFORMATION OF TWO STAGE TRIGGER INTO SINGLE STAGE TRIGGER

⚠ WARNING!



Mortal danger due to automatic firing! Automatic shooting and malfunctions due to minimally set trigger weight and too-low sear engagement.

- ▶ Do not set the trigger weight too low.
- ▶ Do not set the sear engagement too low.

Set the trigger as follows:

- ▶ Unscrew the first stage set screw [A1] to the left until the maximum first stage length is set.
- ▶ Cock.
- ▶ Turn the set screw [A2] (two stage) to the left until the trigger releases.

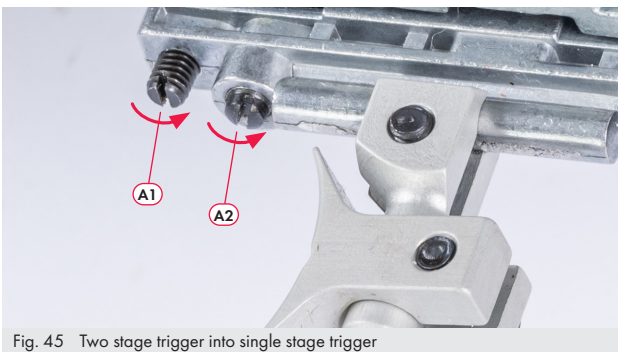

Fig. 45 Two stage trigger into single stage trigger

- ▶ Turn the set screw [A2] approx. ¼ turn from this position to the right.

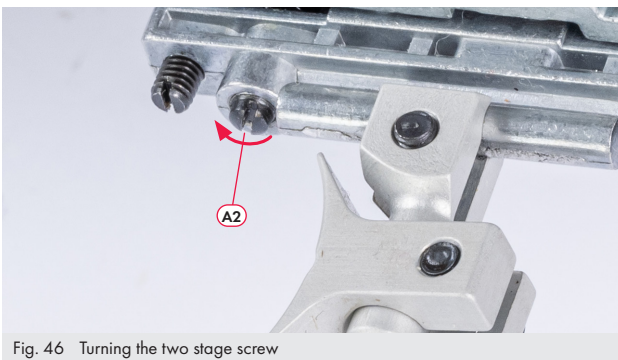

Fig. 46 Turning the two stage screw

- ✓ The trigger is now set directly; there is no more first stage travel.

8.4.1.2.12. TRANSFORMATION FROM SINGLE STAGE TRIGGER TO TWO STAGE TRIGGER

- ▶ Turn trigger stop set screw [A4] approx. 2 ½ turns to the left (set max. trigger stop length).

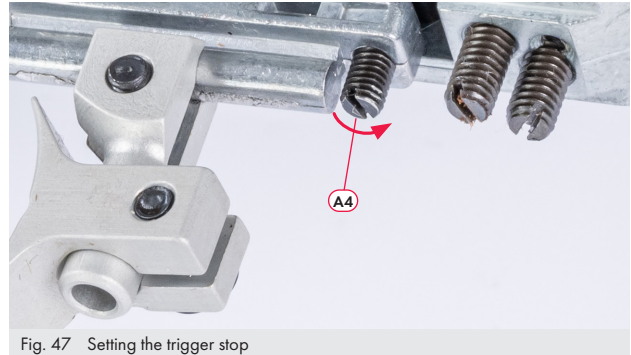

Fig. 47 Setting the trigger stop

- ▶ Release the trigger and cock the rifle; (See chapter "8.1.2. Cocking the bolt" on page 9).
- ▶ Turn the two stage set screw [A2] approx. 2 ½ turns to the right.

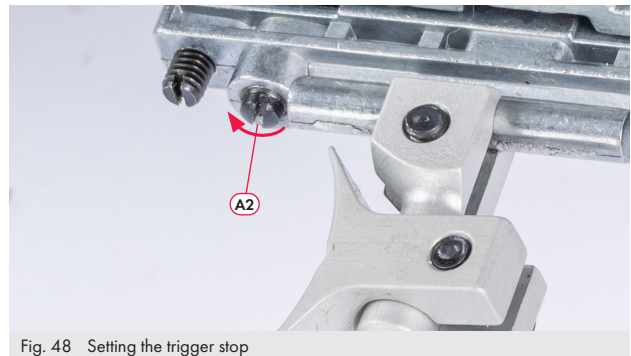

Fig. 48 Setting the trigger stop

- ✓ The two stage is now palpable.
- ▶ To set the optimal sear engagement, proceed according to the instructions in (See chapter "8.4.1.2.5. Sear engagement" on page 19).
- ▶ Set possible first stage travel, trigger stop, trigger weight, and weight of first stage to the desired values.

8.4.1.3. ELIMINATING FAULTS IN THE TRIGGER

NOTE



In case of malfunctions due a maladjusted trigger, proceed as follows:

- ▶ After each change, the trigger function must be checked.
- ▶ If the malfunction has been eliminated, check the desired trigger values and adjust again if necessary.

8.4.1.3.1. THE TRIGGER CATCHES THE FIRING PIN, BUT DOES NOT RELEASE WHEN PULLED

- ▶ Check whether the trigger's safety has been released.
- ▶ Check whether the trigger cam [A7] is present and screwed on properly.
- ▶ Trigger stop set screw [A4] is tightened a few turns too far (turn screw [A4] a few turns to the left until the firing pin releases again when releasing the trigger).

8.4.1.3.2. THE TRIGGER DOES NOT CATCH THE FIRING PIN

The first stage set screw [A1] is tightened a few turns too far.

- ▶ Check whether the tension spring is undamaged and attached correctly.

8.4.1.3.3. THE SINGLE STAGE TRIGGER IS SET TOO SHORT

- ▶ Turn the two stage set screw [A2] stepwise by ¼ turns to the right until the firing pin [V9] is caught.

8.4.1.3.4. THE CATCH LEVER RETAINING SPRING IS TOO WEAK OR DEFECTIVE

- ▶ The trigger must be sent to the factory for repair.

8.4.1.4. DRY FIRING DEVICE

The firing pin [V9] is set lengthwise at the factory so that it ignites the cartridge safely. With longer training without cartridge or receiver in the chamber, the firing pin or stock edge can be damaged. Therefore, a self-contained receiver (replace after approx. every 5 shots) or a firing pin for dry firing (1807T-12) should always be used.

With this device, it is possible to train for competition at any time without using ammunition.

(See chapter "8.1.5. Maintenance of the bolt" on page 11) for instructions on how to remove the firing pin.

8.4.1.5. MAINTENANCE OF THE TRIGGER

- ▶ Keep trigger dry and dust-free (the release links were coated with long-lasting grease by ANSCHÜTZ).
- ▶ Never wash out the insides of the trigger with a spray or oil to prevent hardening, sticking or soiling of the trigger parts.

 When maintaining the firearm no dirt, solvent residues, greases or unsuitable oils may get into the trigger assembly. ANSCHÜTZ recommends cleaning the firearm so that it lies on its side or with the stock upwards, which prevents damage to the trigger assembly.

- ☛ Please heed the general maintenance notes!

8.5. BARRELED ACTION MOUNTING AND STOCK SETTINGS

NOTE!



Do not tighten the fastening screws too tightly to prevent damage to the threads and grooved receiver.

8.5.1. PRECISE STOCKS / PRECISE BENCHREST STOCKS

8.5.1.1. COMPONENTS / DEFINITIONS



Fig. 49 Component definition 54.30 / 1913 / 1907

SV Barreled action bedding screws SY Barreled action
HS Hand stop VS Fore-end screws

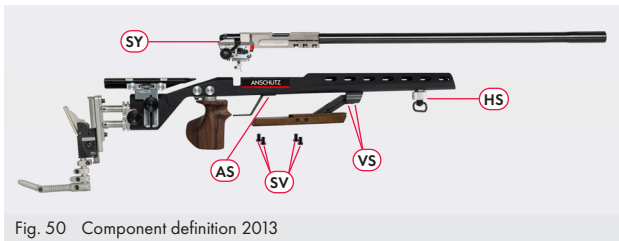

Fig. 50 Component definition 2013

SV Barreled action bedding screws VS Fore-end screws
HS Hand stop AS Trigger guard screw
SY Barreled action

8.5.1.2. ASSEMBLY / DISASSEMBLY OF STOCK AND BARRELED ACTION

8.5.1.2.1. ASSEMBLY / DISASSEMBLY OF STOCK AND BARRELED ACTION FOR 54.30, 1913, AND 1907 BARRELED ACTIONS

- ▶ Loosen both set screws [VS] for the fore-end raiser block.

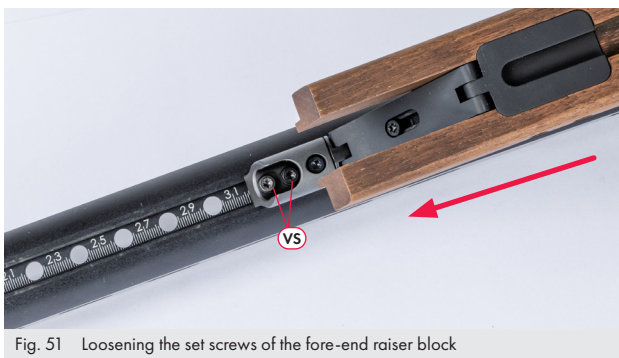

Fig. 51 Loosening the set screws of the fore-end raiser block

- ▶ Push the fore-end raiser block toward the front in the direction of the arrow.

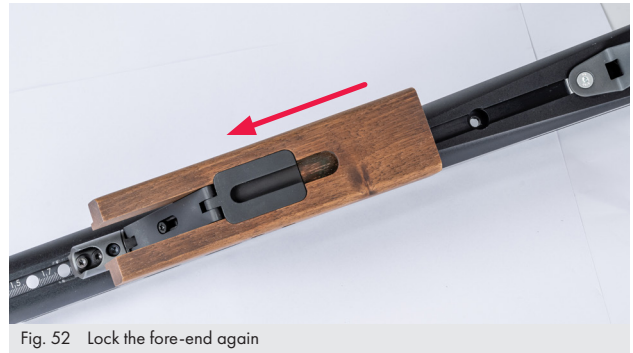

Fig. 52 Lock the fore-end again

- ▶ Tighten both set screws [VS] for the fore-end raiser block.
- ▶ For the Precise support stock, loosen both fore-end screws and push the benchrest rail forward in order to reach the barreled action bedding screws.

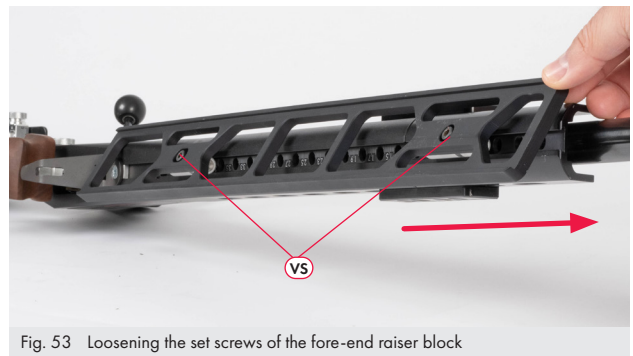

Fig. 53 Loosening the set screws of the fore-end raiser block

- ▶ Loosen both barreled action bedding screws [SV].



Fig. 54 Loosening the barreled action bedding screws

- ▶ The barreled action is now loosened and it can be removed carefully.



Fig. 55 Removing the barreled action

- ✓ The barreled action and stock are separated.
- ▶ The mounting of stock and barreled action is done in the reverse order with a tightening torque of 5 Nm.

8.5.1.2.2. ASSEMBLY / DISASSEMBLY OF STOCK AND BARRELED ACTION FOR 2013 BARRELED ACTIONS

- ▶ Loosen both set screws [VS] for the fore-end raiser block.

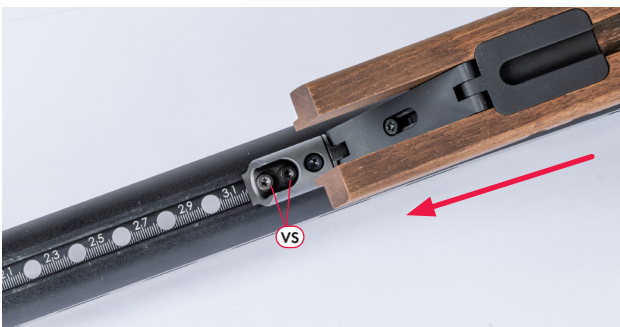

Fig. 56 Loosening the set screws of the fore-end raiser block

- ▶ Push the fore-end raiser block toward the front in the direction of the arrow.



Fig. 57 Lock the fore-end again

- ▶ Tighten both set screws [VS] for the fore-end raiser block.

- ▶ Loosen the trigger guard and move forward in order to access the four stock barreled action bedding screws.

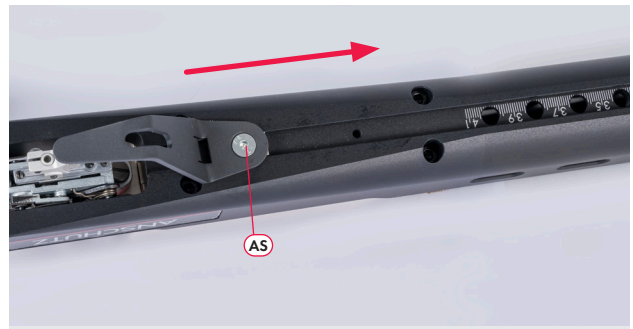

Fig. 58 Loosening the trigger guard screw

- ▶ Loosen the four barreled action bedding screws [SV].

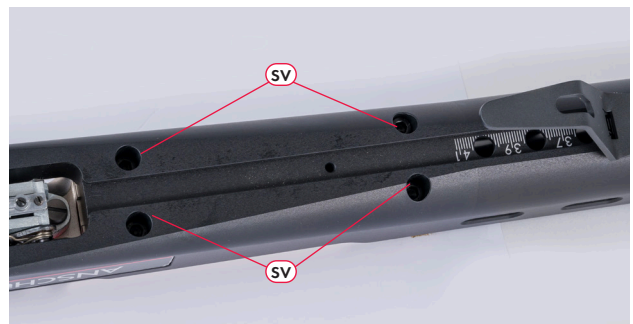

Fig. 59 Moving the trigger guard, loosening the barreled action bedding screws

- ▶ The barreled action is now loosened and it can be removed carefully.



Fig. 60 Removing the barreled action

- ✓ The barreled action and stock are separated.
- ▶ The mounting of stock and barreled action is done in the reverse order with a tightening torque of 5 Nm.

8.5.1.3. ADJUSTING THE BUTT PLATE AND BUTT PLATE CARRIER

8.5.1.3.1. COMPONENTS / DEFINITIONS

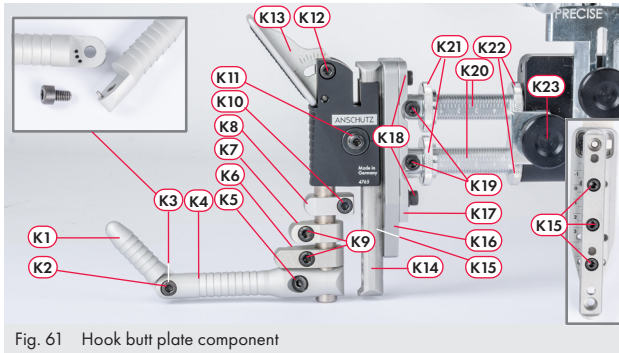

Fig. 61 Hook butt plate component

K1 Swivel hook	K13 Shoulder flap
K2 Pivot screw	K14 Guide
K3 Parallel pin	K15 Pivot screws (3x)
K4 Hook	K16 Aluminum spacer
K5 Pivot screws M5x12	K17 Guide plate
K6 Filling piece large (39 mm)	K18 Pivot screws M5x12
K7 Filling piece medium (30.5 mm)	K19 Pivot screws M5x12
K8 Filling piece small (28 mm)	K20 (Aluminum) pillars 90 mm
K9 Pivot screws M5x10	K21 Precise lock nut
K10 Pivot screws M5x12	K22 Precise adjusting nut
K11 Pivot screws M5x25	K23 Clamping screw for butt plate clamping
K12 Pivot screws M5x25	

8.5.1.3.2. ADJUSTING THE SWIVEL HOOK

- ▶ To adjust the swivel hook [K1], loosen the pivot screw [K2], then the parallel pin [K3] can be adjusted accordingly.
- ▶ Then tighten the pivot screw [K2] again.

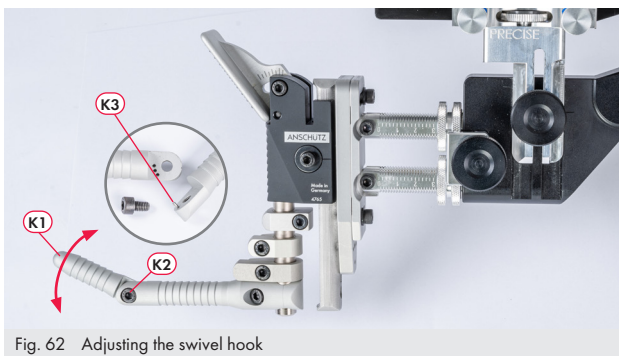

Fig. 62 Adjusting the swivel hook

8.5.1.3.3. ADJUSTING THE HOOK AND FILLING PIECES

- ▶ The hook [K4] can be adjusted after loosening the pivot screw [K5].
- ▶ The filling pieces "large" [K6] and "medium" [K7] can be adjusted after loosening the pivot screws [K9].
- ▶ The filling piece "small" [K8]; can be adjusted after loosening the pivot screws [K10].

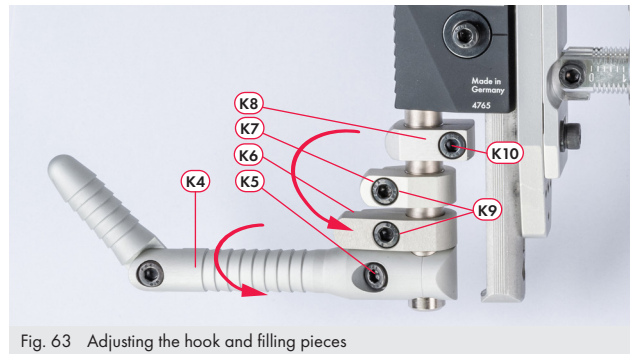

Fig. 63 Adjusting the hook and filling pieces

8.5.1.3.4. ADJUSTING THE SHOULDER FLAP

- ▶ To adjust the desired angle of the shoulder flap [K13], loosen the pivot screw [K12]. Then tighten the pivot screw again.

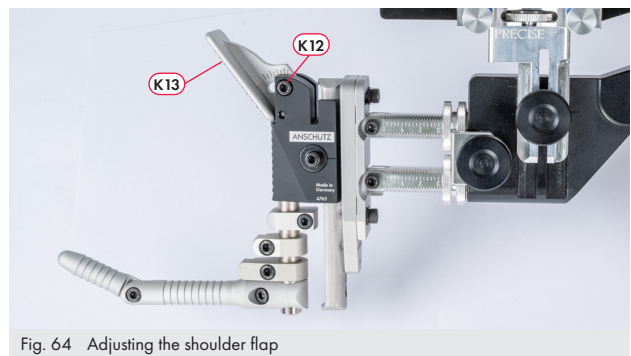

Fig. 64 Adjusting the shoulder flap

8.5.1.3.5. ADJUSTING THE TILTING

- ▶ To tilt the whole butt plate, loosen the pivot screw [K11] and make the desired settings. Then tighten the pivot screw [K11] again.

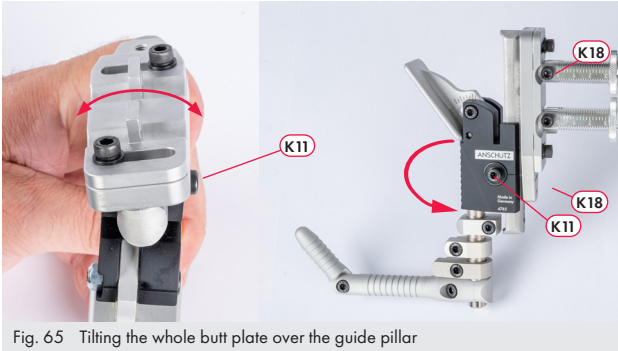

Fig. 65 Tilting the whole butt plate over the guide pillar

- ▶ To tilt the butt plate from the middle, loosen the pivot screw [K18] and make the desired settings. Then tighten the pivot screw [K18] again.

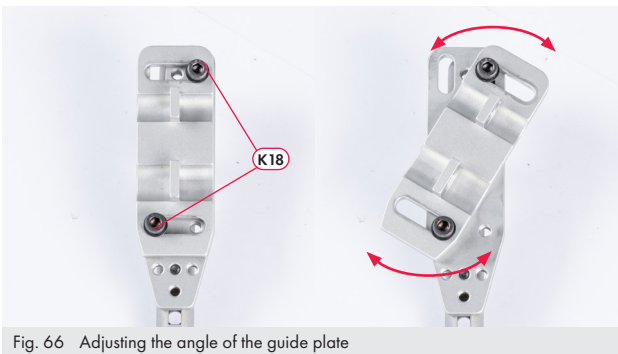

Fig. 66 Adjusting the angle of the guide plate

8.5.1.3.6. ADJUSTING THE HEIGHT

- ▶ To adjust the height of the whole butt plate, loosen the pivot screw [K11] and make the desired settings. Then tighten the pivot screw [K11] again.

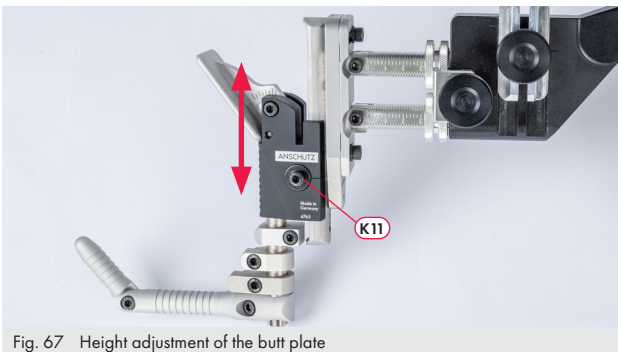

Fig. 67 Height adjustment of the butt plate

8.5.1.3.7. LENGTH ADJUSTMENT OF THE BUTT PLATE CARRIER

- ▶ The rough adjustment of the butt plate carrier is done by loosening the clamping screw [K23]. Loosen the clamping screw and make the rough adjustment of the stock.
- ▶ The fine length adjustment is done by turning the lock nut [K21] and adjusting nut [K22].
- ▶ Then fasten the desired length setting again with the clamping screw [K23]

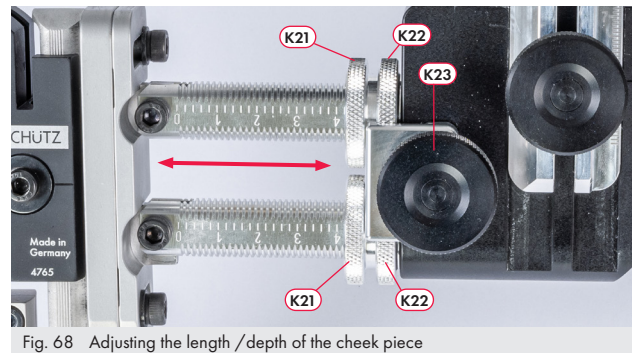

Fig. 68 Adjusting the length / depth of the cheek piece

8.5.1.3.8. TILT OF THE BUTT PLATE CARRIER

- ▶ By loosening the clamping screw [K23], pivot screws [K19], the adjustment of lock nut [K21] and adjusting nut [K22], it is possible to adjust the tilt of the butt plate carrier.

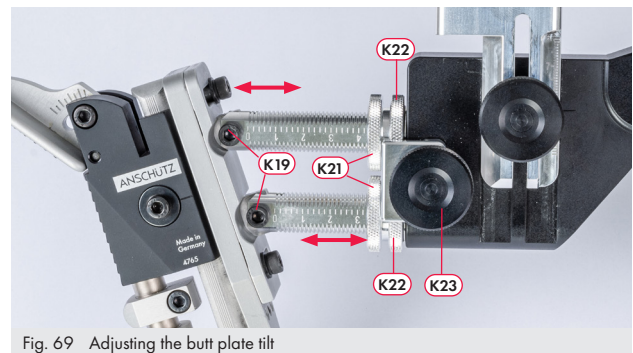
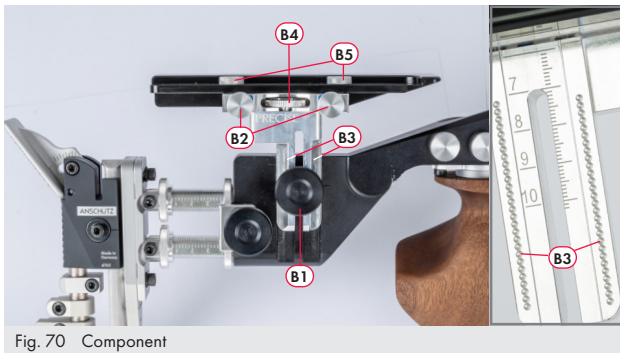

Fig. 69 Adjusting the butt plate tilt

8.5.1.4. ADJUSTING THE CHEEK PIECE

8.5.1.4.1. COMPONENTS/DEFINITIONS



- | | |
|--|---|
| B1. Clamping screw for cheek clamping | B4. Fine adjustment wheel for the cheek piece cover |
| B2. Adjusting screws for cheek piece cover | B5. Slotted screws for cheek piece cover |
| B3. Precise ball catch | |

8.5.1.4.2. ADJUSTING THE HEIGHT

- ▶ The rough adjustment of the cheek piece is done by loosening the clamping screw [B1]. When adjusting the height, the ball catch [B3] serves as an alignment aid.
- ▶ The fine adjustment of the cheek piece is done by turning the fine adjustment wheel [B4].

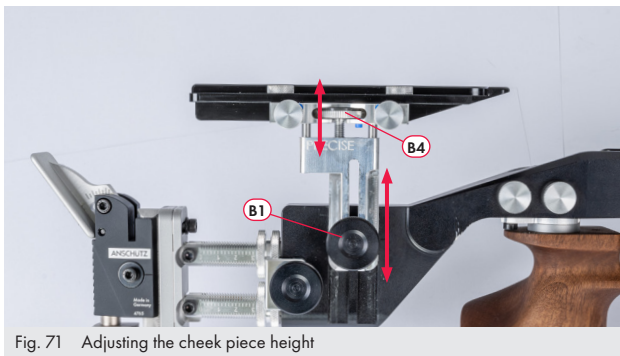

8.5.1.4.3. ADJUSTING THE CHEEK SUPPORT

- ▶ By loosening the slotted screws [B5], it is possible to push the cheek support forward and backward.

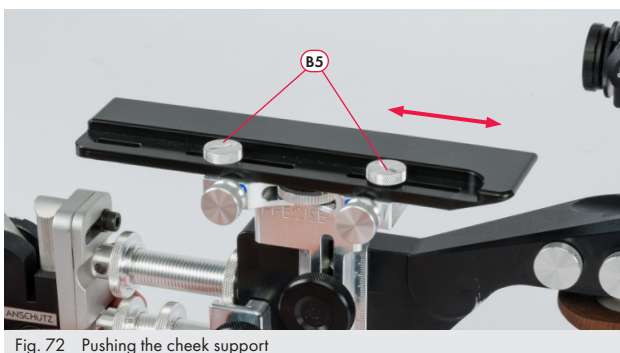

- ▶ By turning the adjustment screws [B2], it is possible to adjust the angle of the cheek piece cover.

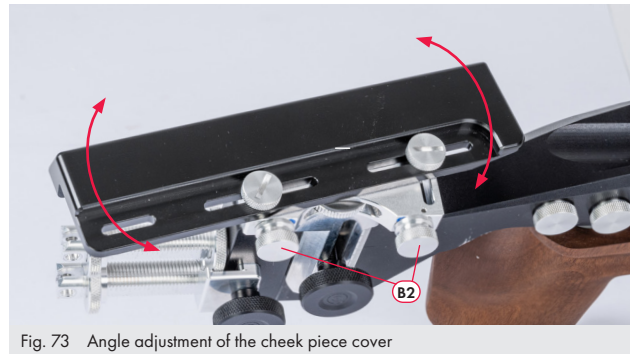

Fig. 73 Angle adjustment of the cheek piece cover

8.5.1.5. ADJUSTING THE GRIP

- ▶ After loosening the grip fastening screw [GBS], the grip can be turned swiveled or the length adjusted in any direction by turning the adjusting screws [S1; S2].
- ▶ Adjust the grip as desired.



Fig. 74 Loosening the grip fastening screw

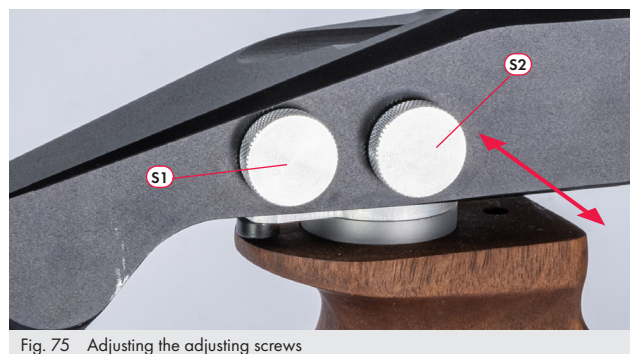

Fig. 75 Adjusting the adjusting screws

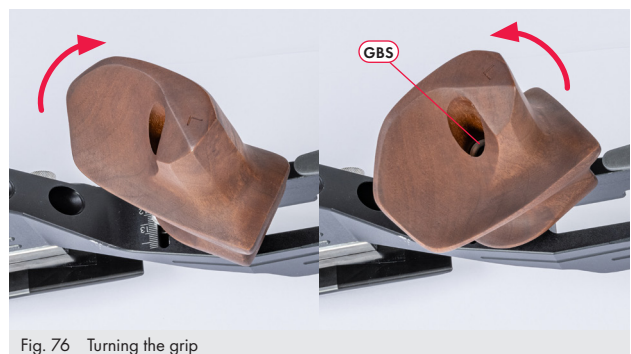



Fig. 76 Turning the grip

- ▶ After adjusting the grip, tighten the grip fastening screw [GBS] again.

NOTE



Tighten the grip fastening screws slightly from time to time since they can settle.

✓ The grip is adjusted.

8.5.1.6. ADJUSTING THE FORE-END RAISER BLOCK

- ▶ Loosen the pivot screws [ZS1] to push the fore-end raiser block lengthwise.

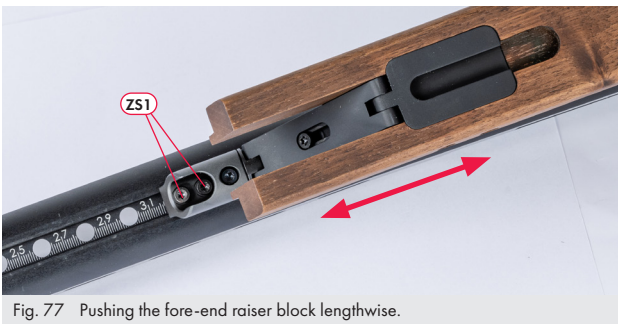

Fig. 77 Pushing the fore-end raiser block lengthwise.

- ▶ Swivel the fore-end raiser block by loosening the pivot screw [ZS2].

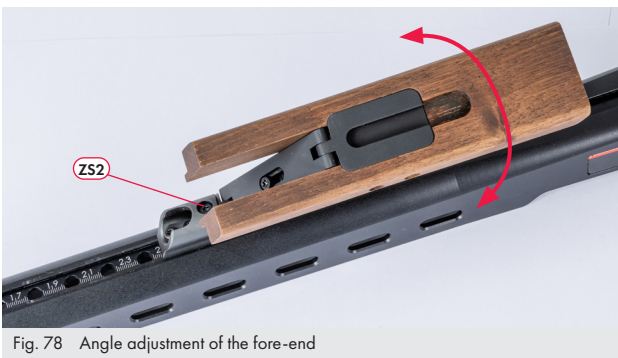

Fig. 78 Angle adjustment of the fore-end

- ▶ Height adjustment the fore-end raiser block by loosening the pivot screw [ZS3].

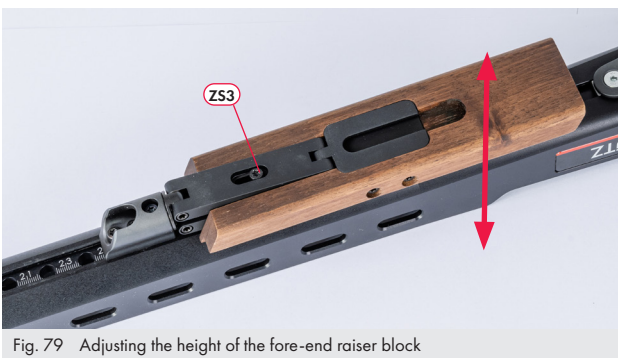

Fig. 79 Adjusting the height of the fore-end raiser block

8.5.1.7. MOUNTING / DISMOUNTING THE HAND STOP

- ▶ To mount the hand stop on the swivel rail, turn the hand stop on the silver base body to release the clamping.
- ▶ Push the hand stop on the swivel rail.
- ▶ By turning the silver base body, you fasten the hand stop.



Fig. 80 Mounting /dismounting the hand stop (left turning)

- ▶ Dismounting the hand stop is done in the reverse order.

8.5.1.8. ADJUSTING THE BENCH REST RAIL (PRECISE BENCHREST)

This setting only affects models with the PRECISE Benchrest stock.

- ▶ Loosen the pivot screws [ZS] and put the bench rest support in the desired position.

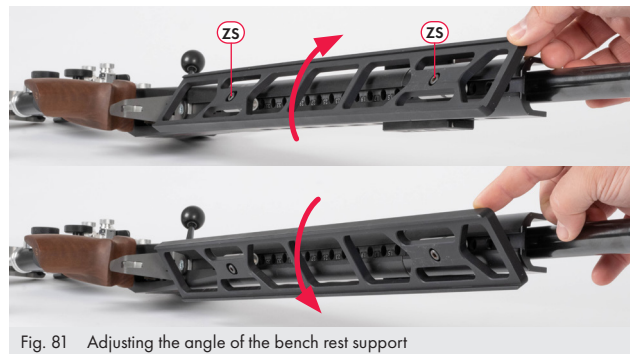

Fig. 81 Adjusting the angle of the bench rest support

- ▶ Tighten the pivot screws again.

8.5.2. KK MATCH

8.5.2.1. COMPONENTS / DEFINITIONS

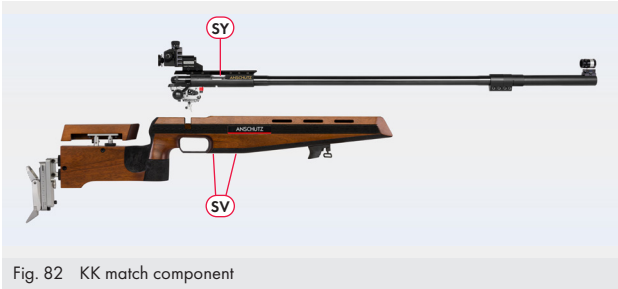

Fig. 82 KK match component

SV. Barreled action bedding screws SY. Barreled action

8.5.2.2. ASSEMBLY / DISASSEMBLY OF STOCK AND BARRELED ACTION FOR 54.30, 1913 AND 1907

- ▶ Loosen both barreled action bedding screws [SV].

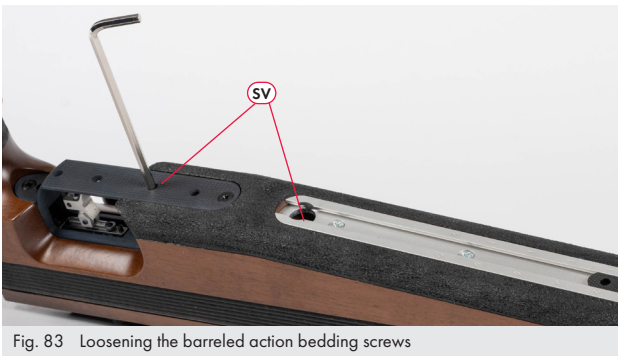

Fig. 83 Loosening the barreled action bedding screws

- ▶ The barreled action is now loosened and it can be removed carefully.



Fig. 84 Removing the barreled action

- ✓ The barreled action and stock are separated.
- ▶ The mounting of stock and barreled action is done in the reverse order with a tightening torque of 4 Nm.

8.5.2.3. ADJUSTING THE BUTT PLATE AND BUTT PLATE CARRIER

8.5.2.3.1. COMPONENTS / DEFINITIONS

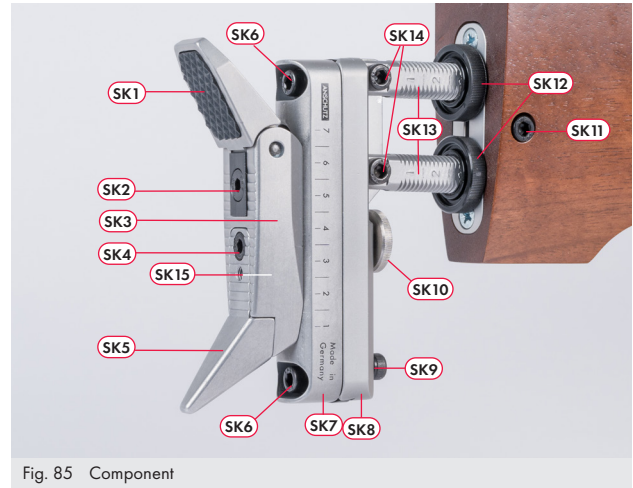

Fig. 85 Component

- | | |
|------------------------------|--|
| SK1. Butt plate | SK10. Adjusting screw cover plate |
| SK2. Butt plate screw | SK11. Pivot screw butt plate carrier |
| SK3. Lower section | SK12. Adjusting nut |
| SK4. Hook screw | SK13. Aluminum pillars |
| SK5. Hook | SK14. Pivot screw for aluminum pillars |
| SK6. Pivot screw guide | SK15. Countersunk head screw for hook height |
| SK7. Guide | |
| SK8. Cover plate | |
| SK9. Pivot screw cover plate | |

8.5.2.3.2. ADJUSTING THE HOOK

- ▶ To adjust the height of the hook [SK5], the butt plate must first be separated from the guide. To do this, first loosen the butt plate screw [SK2].
- ▶ Remove the butt plate.



Fig. 86 Removing the butt plate from the guide

- ▶ To adjust the height of the hook [SK5], first the lower section [SK3] must be removed. To do this, loosen the pivot screw [SK4].
- ▶ Then loosen the countersunk head screw [SK15] on the back.
- ▶ Align the hook [SK5] in the desired position and then fasten it with the screws [SK4] and [SK15].

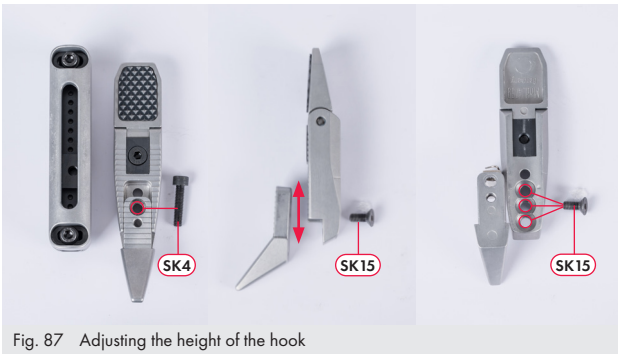

Fig. 87 Adjusting the height of the hook

- ✓ The height of the hook is adjusted.
- ▶ Mount the butt plate again using the screw [SK2] on the guide. For this, the screw [SK2] must be screwed into the slot key [NS].



Fig. 88 Fastening the butt plate on the guide

8.5.2.3.3. ADJUSTING THE SHOULDER FLAP

- ▶ By turning the pivot screw [SK2], it is possible to adjust the angle of the butt plate.



Fig. 89 Lower section: Adjusting the shoulder flap

8.5.2.3.4. ADJUSTING THE TILTING

- ▶ The butt plate can be tilted from the middle. To do this, loosen the screws [SK6].
- ▶ To reach the screws [SK6], it may be necessary to loosen the screw [SK2] and push the butt plate down or up.



Fig. 90 Tipping the guide rail

- ▶ To tilt the butt plate along the guide, loosen the screw [SK2]. Adjust the desired tilt and tighten the screw again [SK2].

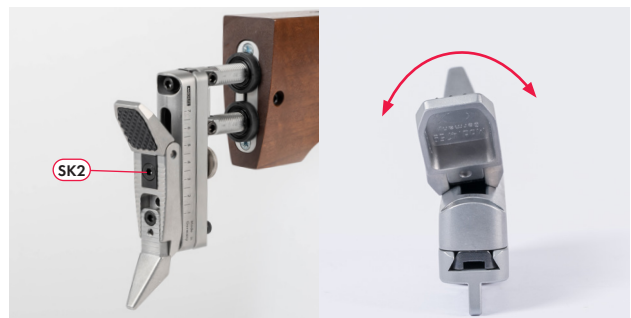

Fig. 91 Lower section: Adjusting the height and angle; adjusting the butt plate

8.5.2.3.5. ADJUSTING THE HEIGHT

- ▶ The elevation adjustment of the guide plate [SK7] is done by loosening the adjusting screw [SK10] and the pivot screw [SK9] of the butt plate carrier.

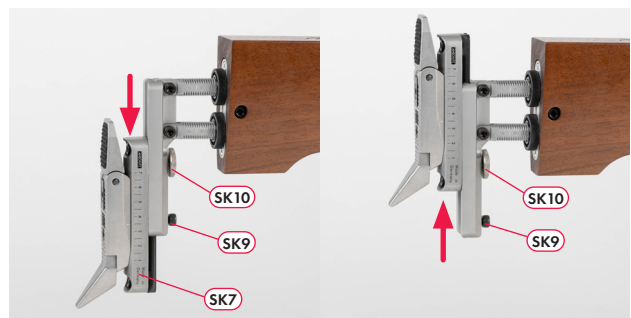

Fig. 92 Adjusting the butt plate height

8.5.2.3.6. LENGTH ADJUSTMENT OF THE BUTT PLATE CARRIER

- ▶ Loosen the pivot screw for the butt plate carrier [SK11], set the desired length.
- ▶ The fine adjustment is done using the adjusting nuts [SK12]. Align them directly on the stock and turn them against the stock. This lengthens or shortens the stock length.
- ▶ Then fasten the pivot screw [SK11] again.

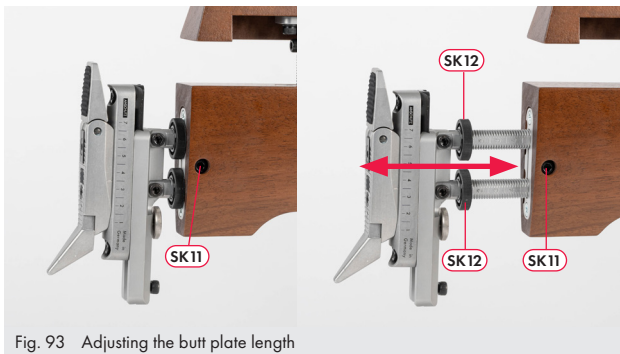

Fig. 93 Adjusting the butt plate length

8.5.2.3.7. TILT OF THE BUTT PLATE CARRIER

- ▶ Loosen the pivot screws [SK14] of the aluminum pillars and the adjusting nuts [SK12] and adjust the butt plate carrier tilt accordingly.



Fig. 94 Adjusting the tilt of the butt plate carrier

- ▶ Then tighten the pivot screws again.

8.5.2.4. ADJUSTING THE CHEEK PIECE

8.5.2.4.1. COMPONENTS / DEFINITIONS

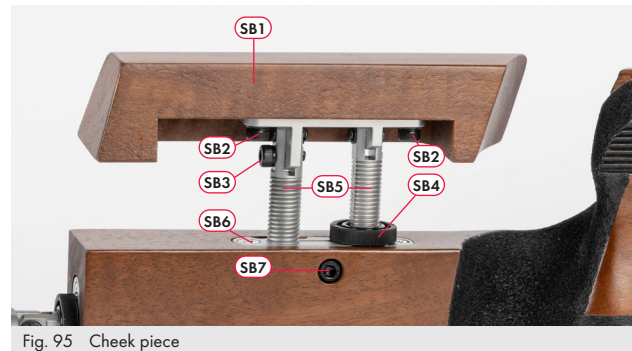

Fig. 95 Cheek piece

- | | |
|--------------------|---------------------------------|
| SB1. Cheek piece | SB5. Clamping pillar |
| SB2. Pivot screw | SB6. Clamping piece |
| SB3. Pivot screw | SB7. Pivot screw clamping piece |
| SB4. Adjusting nut | |

8.5.2.4.2. ADJUSTING THE HEIGHT

- ▶ Adjust the cheek piece height by loosening the pivot screw [SB7] of the clamping piece and adjusting the adjusting nut [SB4].

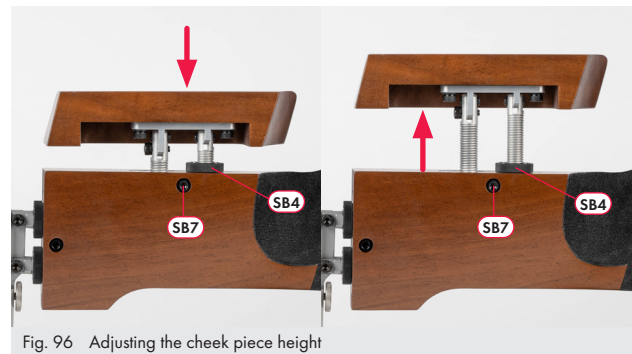

Fig. 96 Adjusting the cheek piece height

8.5.2.4.3. ADJUSTING THE CHEEK SUPPORT

- ▶ To adjust the angle of the cheek piece, loosen the pivot screw [SB3] and then tighten it again.

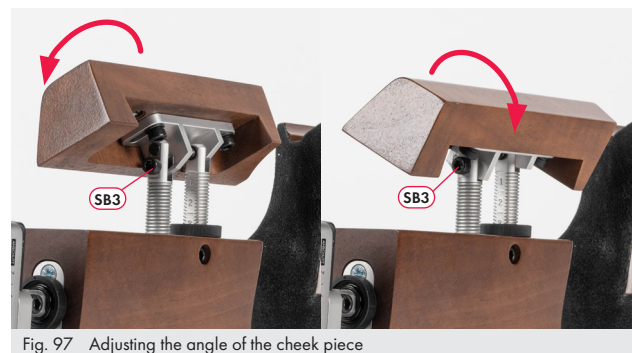

Fig. 97 Adjusting the angle of the cheek piece

- ▶ By loosening the pivot screw [SB2], it is possible to swivel the cheek piece.

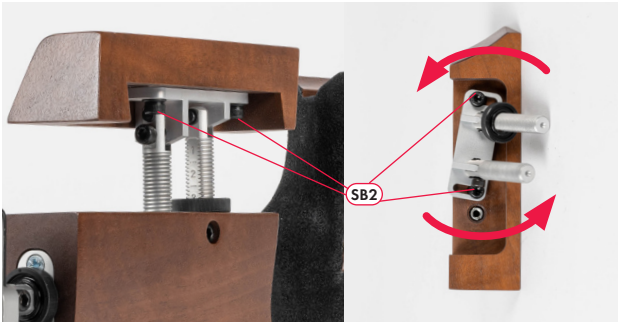

Fig. 98 Swiveling the cheek piece

- ▶ The cheek piece support can be moved by loosening both pivot screws [SB2] on the cheek piece extension. There are two additional threads on the underside of the cheek support on which the cheek piece extension can be mounted.

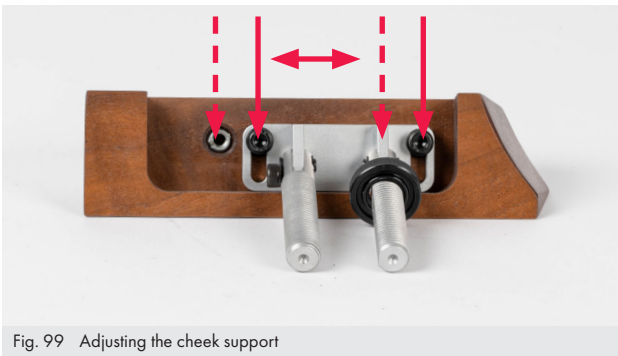

Fig. 99 Adjusting the cheek support

8.5.2.5. MOUNTING / DISMOUNTING THE HAND STOP

- ▶ Carefully insert the hand stop into the rail and fasten it in the desired position on the underside using the screw.



Fig. 100 Attaching the hand stop

8.5.3. BENCHREST

8.5.3.1. COMPONENTS / DEFINITIONS

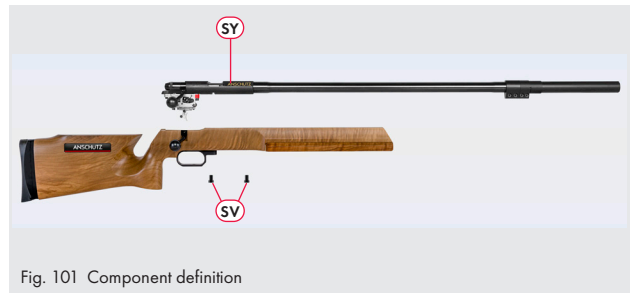

Fig. 101 Component definition

SV Barreled action bedding screws SY Barreled action

8.5.3.2. ASSEMBLY / DISASSEMBLY OF STOCK AND BARRELED ACTION FOR 54.30, 1913 AND 1907

- ▶ Loosen both barreled action bedding screws [SV].



Fig. 102 Removing the barreled action

- ▶ The barreled action is now loosened and it can be removed carefully.



Fig. 103 Removing the barreled action

- ✓ The barreled action and stock are separated.
- ▶ The mounting of stock and barreled action is done in the reverse order with a tightening torque of 4 Nm.

8.5.3.3. ADJUSTING THE BUTT PLATE

- ▶ Loosen the pivot screw [ZS] and guide cheek piece into the appropriate position. Then tighten the pivot screw [ZS] again.



Fig. 104 Adjusting the cheek piece

8.5.4. MAINTENANCE / CLEANING OF THE STOCK

- ☛ Please heed the general maintenance notes!

It is important to keep the stock clean and free of moisture. If your stock should get wet, we recommend cleaning it with a soft cloth and drying it completely. For this, it may be appropriate to dismount the stock and barreled action.

For wood stocks, use only suitable cleaning and maintenance products for this purpose. You can get appropriate stock care products at a dealer.

The PRECISE stocks are made from high-quality aluminum. It should only be cleaned with a soft, moist, and lint-free cloth and /or with mild soap solution.

Under all circumstances, avoid rough or abrasive cleansers and cleaning utensils.

Do not expose wood or aluminum stocks frequently to full sunlight. Storage in full sunlight ensures changes of the color and possibly also structure of the material.

! NOTE!



Firearm oils are not suitable for stock maintenance. Use appropriate stock care products and note the instructions of the manufacturer in question.

! NOTE!



Keep the stock dry, free of water, and avoid condensation formation. Pay attention that the stock does not come into contact with any solvents, cleaning products or other substances. Do not affix any stickers or other objects to the stock. This can cause damage to the stock surface.

! NOTE!



Please note the cleaning instructions, the care products, and follow the instructions of the manufacturer in question.

8.6. BARREL

8.6.1. MOUNTING OF THE MUZZLE TUBE (OPTIONAL)

⚠ CAUTION



Do not dismount the muzzle tube!

- ▶ Loosen the pivot screws [ZMR] of the muzzle tube a bit in order to be able to plug the tube in the barrel.

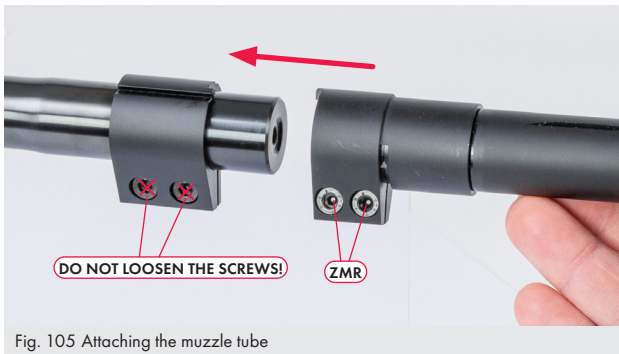

Fig. 105 Attaching the muzzle tube

- ▶ Tighten the pivot screws [ZMR] a little after plugging in.

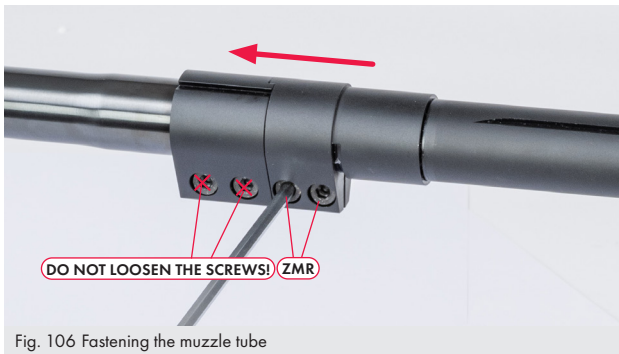

Fig. 106 Fastening the muzzle tube

8.6.2. CLEANING THE BARREL

⚠ CAUTION



Never pull the brush back and forth in the barrel.

ℹ NOTE!



Heed the operating instructions of the cleaner!

ℹ NOTE!



After using cleaning agents that contain ammonia, be sure to re-oil the barrel to prevent the risk of corrosion.

- Please heed the general maintenance notes!

To clean the barrel in case of light soiling, use a plastic brush.

- ▶ Oil the plastic brush slightly and push from the chamber side out with a suitable cleaning rod through the barrel.
- ▶ To clean the barrel in case of heavy soiling, use a bronze brush and a suitable barrel cleaner.

- ⚠ Caution: Never pull the brush back and forth in the barrel.



Fig. 107 Plastic brush

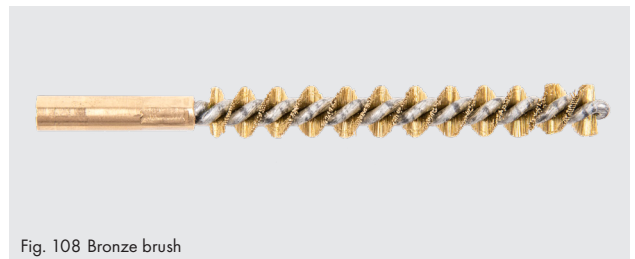

Fig. 108 Bronze brush

- ▶ To dry the barrel, pull a woolen swab through the barrel several times.

8.7. SIGHTS / MOUNTING

NOTE!



Do not tighten the fastening screws too tightly to prevent damage to the threads and grooved receiver.

8.7.1. REAR SIGHT (OPTIONAL)

CAUTION



Property damage!
Only work on the screws that are depicted below. All other screws may not be unscrewed!

Failure to follow these instructions voids the guarantee and any claims for damages.

8.7.1.1. COMPONENTS / DEFINITIONS

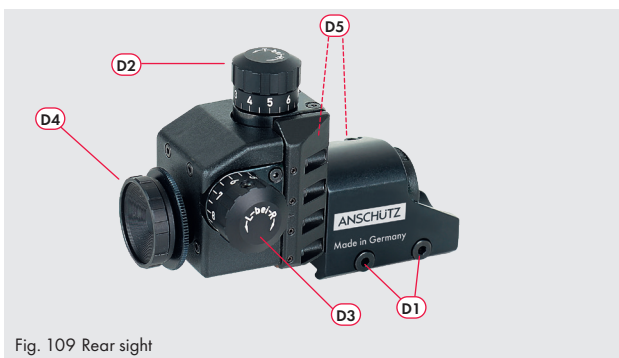

Fig. 109 Rear sight

- | | |
|--|-----------------------------|
| D1. Clamping screws for rail clamping | D3. Rotary knob for windage |
| D2. Rotary knob for elevation adjustment | D4. Sight disc aperture |
| | D5. Pivot screw for tilting |

8.7.1.2. MOUNTING / DISMOUNTING THE REAR SIGHT

- ▶ Push the rear sight onto the 11 mm rear raiser bridge [DB] of the barreled action receiver.



Fig. 110 Attaching and pushing on the rear sight

- ▶ Select the right eye distance.
- ▶ Screw the rear sight clamping screws [D1] to the grooved receiver.
- ▶ Tighten the screws with 2.5 Nm.
- ▶ Assembly is done in the reverse order.

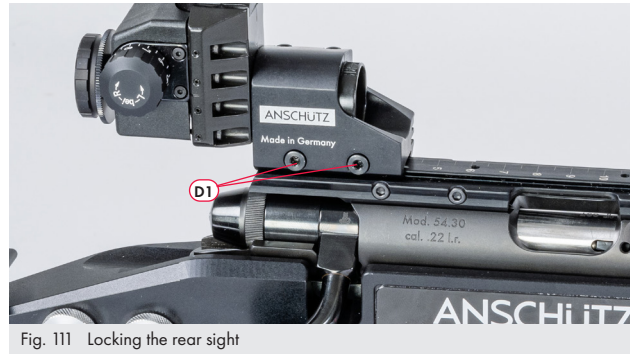

Fig. 111 Locking the rear sight

- ✓ The rear sight is attached and mounted.

8.7.1.3. ELEVATION AND WINDAGE OF THE SHOT POINT POSITION

Take a few sighting shots at a target to determine the target position. The elevation and windage set screws have clicks. The shot point position changes from click to click.

The adjustment of the shot point position is done as follows:

- ▶ Elevation adjustment for high shot:
Turn rotary knob in "h" direction.
- ▶ Elevation adjustment for low shot:
Turn rotary knob in "T" direction.
- ▶ Windage for right shot:
Turn rotary knob in "R" direction.
- ▶ Windage for left shot:
Turn rotary knob in "L" direction.



Fig. 112 Elevation and windage of the shot point position

8.7.1.4. ZERO ADJUSTMENT

After shooting the rifle, the two set screws of the rear sight can be set to the position (0).

- ▶ Loosen the set screw [NJ].
- ▶ Position the rotary knobs to scale value "0."
- ▶ Tighten the set screw on the rotary knob again with max. 2 Nm.



Fig. 113 Zero adjustment

8.7.1.5. TILTING THE REAR SIGHT

- ▶ The rear sight can be tilted to the side. To do this, loosen both pivot screws [D5] and tilt the rear sight into the desired position. Then tighten the pivot screws [D5] again.

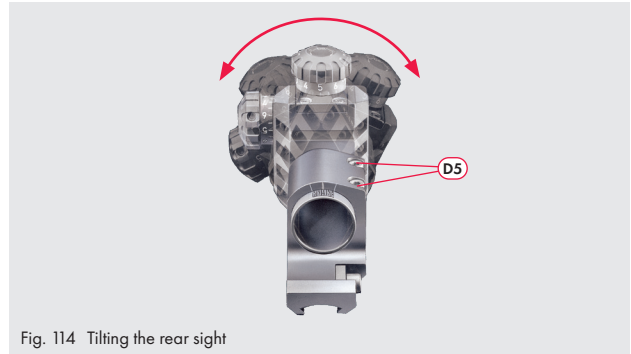

Fig. 114 Tilting the rear sight

8.7.1.6. MAINTENANCE AND CLEANING OF THE REAR SIGHT

- ☛ Please heed the general maintenance notes!

If the rear sight got wet or dirty, clean it with a soft, lint-free cloth and dry it. Moving parts can be oiled at the movement points (e.g., hinges, contact areas, etc.) minimally with a high-quality gun oil. Any excess oil should be removed carefully.

8.7.2. FRONT SIGHT (OPTIONAL)

NOTE!



Do not tighten the fastening screws too tightly to prevent damage to the threads and grooved receiver.

WARNING!



Mortal danger due to work on the muzzle

- ▶ Make sure that there is no ammunition in the cartridge chamber!
- ▶ Open or remove the bolt in order to guarantee completely safe work on the muzzle.

8.7.2.1. COMPONENTS / DEFINITIONS



Fig. 115 Component

- | | |
|-------------------------------|------------------------|
| K1. Prism block for elevation | K3. Clamping piece |
| K2. Pivot screw | K4. Pivot screws M3x16 |

8.7.2.2. MOUNTING / DISMOUNTING THE FRONT SIGHT

- ▶ (Optional) pushing on the prism block for elevation [K1]



Fig. 116 Pushing on the prism block for elevation

- ▶ Fastening the prism block for elevation [K1] by tightening the pivot screw [K2].

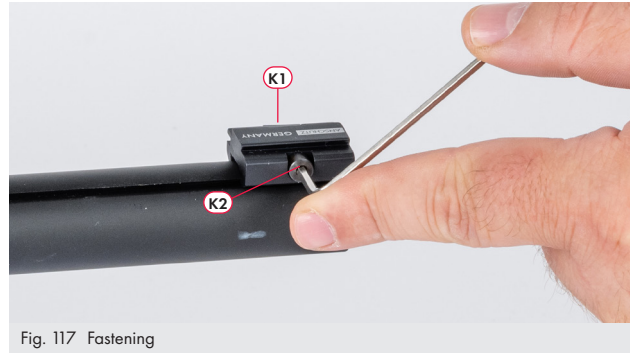

Fig. 117 Fastening

- ✓ The prism block for elevation is now fastened.
- ▶ Push the front sight [KT] onto the prism block for elevation [K1].

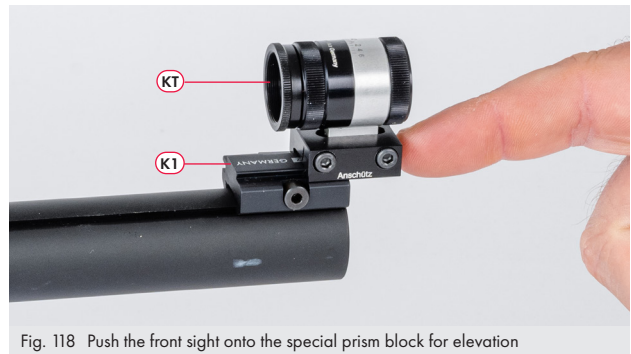

Fig. 118 Push the front sight onto the special prism block for elevation

- ▶ Fasten the clamping piece [K3] with the pivot screws [K4].

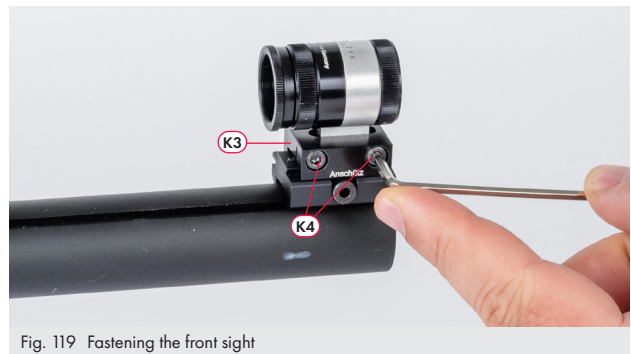

Fig. 119 Fastening the front sight

- ✓ The front sight is now mounted on the prism block for elevation.
- ▶ Assembly is done in the reverse order.

8.7.2.3. MOUNTING / DISMOUNTING THE REAR RAISER BRIDGE

- ▶ Push the rear raiser bridge [DB] onto the receiver [HL].



- ▶ Fasten the rear raiser bridge [DB] with the screws [VS].

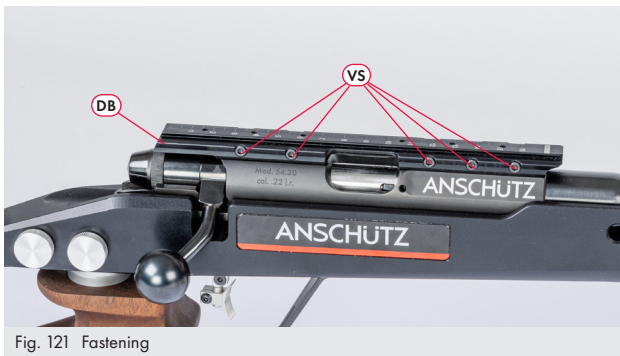

- ✓ The rear raiser bridge is now fastened and ready for use.
- ▶ Assembly is done in the reverse order.

9. TROUBLESHOOTING

⚠ CAUTION!



In case of malfunction (shots not fired, etc.), the rifle must be unloaded, the safety set, and it must be brought to a specialized dealer/gunsmith or sent to ANSCHÜTZ.

10. DISPOSAL



Disposal of the firearm must be done demonstrably by a specialized dealer/gunsmith.

11. MISCELLANEOUS

Additional information is available on the Internet at www.anschuetz-sport.com. ANSCHÜTZ will also be glad to inform you about news about this and other products with the ANSCHÜTZ newsletter, to which you can subscribe for free on the Internet.

Included with your firearm is a quality control card with the original test fire group.



Fig. 122 Control card shot with premium hunting ammunition (Fig. similar)

ⓘ NOTE!



Please wash your hands for hygienic reasons each time after you use the rifle, as there can be oils, greases, and contamination on the rifle.

12. SHOOTING PERFORMANCE

The shooting performance of a rifle depends on many factors. An important factor here is the ammunition. Not every barrel shoots equally well with every type of ammunition; there can be significant differences in performance.

The sights and their mounting is just as important. Parallax, loose sighting, defects in the sighting adjustment, and non-optimal mounting are the most frequent causes of unsatisfactory shooting performance.

That's why only telescopic sights and mounts mounted by a specialist are used and the ammunition is coordinated with those on your rifle.

Even ammunition from the same maker and the same filling can produce different shooting performance and shooting patterns from batch to batch and rifle to rifle. With optimally selected ammunition, sights, and mounting, we guarantee the outstanding shooting performance of our rifles.

See guarantee card.

Please also note that every attachment or accessory (regardless of the manufacturer), such as sound moderators, muzzle brakes, and sights contribute to the precision and shooting performance and can affect it.

ⓘ NOTE!



Every bolt is adapted to the associated rifle in order to achieve optimal shooting performance. This is why, and for safety, the bolts may not be exchanged.

13. GUARANTEE CARD

<div data-bbox="379 353 625 412" data-label="Text"><p>ANSCHÜTZ</p></div> <div data-bbox="419 416 587 434" data-label="Text"><p>EINFACH EINS WERDEN!</p></div> <div data-bbox="258 465 745 508" data-label="Section-Header"><h3><<< GARANTIE >>></h3></div> <div data-bbox="450 528 553 553" data-label="Section-Header"><h4>1. Material:</h4></div> <div data-bbox="199 557 804 813" data-label="Text"><p>Dieser Artikel wurde zum Verkauf freigegeben, nachdem er selbst, seine Materialien und Einzelteile strenge Kontrollen durchlaufen haben, oder das Gewehr beim Beschuss seine Haltbarkeit und Funktion unter Beweis gestellt hat. Die J.G. ANSCHÜTZ GmbH & Co. KG übernimmt für zwei Jahre volle Garantie auf Material- oder Bearbeitungsfehler (ausgenommen Schaft- und Federbrüche), sofern ein Mangel nachweisbar bereits zum Zeitpunkt der Übergabe des Artikels vorlag. Für Mängel, die auf unsachgemäße Behandlung oder auf Reparaturen zurückzuführen sind, steht die J.G. ANSCHÜTZ GmbH & Co. KG nicht ein. Die Garantieleistung steht in unserer Wahl in Nachbesserung oder Neulieferung. Schadensersatzansprüche – aus welchem Rechtsgrund auch immer geltend gemacht – sind ausgeschlossen.</p></div> <div data-bbox="424 844 576 873" data-label="Section-Header"><h4>2. Schussleistung:</h4></div> <div data-bbox="199 875 804 1176" data-label="Text"><p>Der Erwerber ist verpflichtet, festgestellte Mängel der Schussleistung innerhalb eines Monats nach dem Neukauf schriftlich bei der J.G. ANSCHÜTZ GmbH & Co. KG unter Vorlage eines eigen erstellten Schussbogens geltend zu machen. Die J.G. ANSCHÜTZ GmbH & Co. KG behält sich vor, das Gewehr an ein unabhängiges Institut zur Überprüfung zu geben (DEVA oder Staatliches Beschussamt). Sollte dort eine hervorragende Schussleistung bestätigt werden, ist die J.G. ANSCHÜTZ GmbH & Co. KG berechtigt, die Kosten der Überprüfung des Gewehrs zu berechnen. Die übernommenen Garantien gelten nicht bei Beschädigungen des Gewehrs durch mechanische Einwirkungen sowie unsachgemäße Handhabung oder Pflege durch den Erwerber. Die Garantie ist ausgeschlossen, wenn das Gewehr durch nicht autorisierte Personen repariert oder verändert wurde. Ebenso entfällt eine Garantie bei Verwendung von wiedergeladener oder nicht CIP-zugelassener Munition.</p></div> <div data-bbox="199 1184 804 1236" data-label="Text"><p>Wir bitten, diese Karte im Garantie-/Schadensfall – von Ihrem Waffenfachgeschäft ausgefüllt und unterschrieben – mit dem Artikel an uns einzusenden.</p></div> <div data-bbox="234 1267 767 1296" data-label="Text"><p>J.G. ANSCHÜTZ GmbH & Co. KG · Jagd- und Sportwaffenfabrik</p></div> <div data-bbox="250 1299 751 1328" data-label="Text"><p>Postfach 1128 · D-89001 Ulm/Germany · www.anschuetz-sport.com</p></div>
<div data-bbox="427 1444 574 1471" data-label="Text"><p>Fabrikations-Nr.:</p></div>
<div data-bbox="411 1541 590 1568" data-label="Text"><p>Datum des Verkaufs:</p></div>
<div data-bbox="443 1641 557 1668" data-label="Text"><p>Gekauft bei:</p></div>

ANSCHÜTZ

EINFACH **EINS** WERDEN!

J.G. ANSCHÜTZ GmbH & Co. KG
Jagd- und Sportwaffenfabrik

Daimlerstraße 12 · 89079 Ulm / Germany

Tel. +49 - (0)731 - 40 12 - 0

Fax +49 - (0)731 - 40 12 - 700

www.anschuetz-sport.com

www.facebook.com/OfficialAnschuetz

www.youtube.com/AnschuetzGmbH

www.instagram.com/AnschuetzGmbH

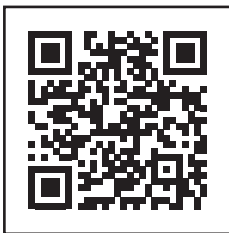

Production and model changes reserved · All colors and sizes approximate · Firearms that require a permit: Supply of firearms only to the holders of a purchasing permit ·
Firearms that do not require a permit: Supply only to persons over 18 years of age
Misprints, errors, and prior sale also reserved © ANSCHÜTZ